

# SOFTWARE DEFINED RADIO PROTOTYPE FOR MULTI-MODE AND MULTI-SERVICE RADIO COMMUNICATION SYSTEMS

Hiroshi HARADA

National Institute of Information and Communications Technology (NICT)  
3-4 Hikarino-oka, Yokosuka, Kanagawa, 239-0847 Japan, E-mail: harada@nict.go.jp

**Abstract**— National Institute of Information and Communications Technology (NICT) has developed a software defined radio platform that consists of FPGA board, CPU board, and RF boards. On the platform, software packages for W-CDMA, IEEE802.11a/b, and digital terrestrial broadcasting have been developed. Each software package consists of physical layer, MAC/DLC layer, IP layer, and application layer part. In this paper the details of SDR platform and its software are introduced. Then, the volume of each software package for FPGAs and CPUs is shown and the minimum size of hardware that realizes communication and broadcasting systems with high-signal-processing-power is discussed. Finally, this paper shows the image and requirement of cognitive radio based on the research results.

## I. INTRODUCTION

A number of wireless access systems have already been available to users. For example, in cellular systems, we can use PDC, GSM, W-CDMA, CDMA2000, and so on. Apart from cellular systems, wireless access systems include high-speed mobile access systems, via wireless LAN using 2.4, 5 and 25GHz bands that are lower-priced and pursue higher-speed at the order of several tens Mbps, and fixed wireless access (FWA) systems using 22, 26, and 38GHz bands that enable transmission rate at over 100 Mbps, though higher in price. Moreover users would like to receive broadcasting services such as high definition digital terrestrial television (HDTV) and radio. It is, however, difficult for a user to use all of these wireless access systems and broadcasting services by a terminal. In addition, communications between different wireless access systems has not been achieved yet. If various systems can be handled flexibly without laborious operation, the optimum access system will be automatically chosen, regardless of wired or wireless, regardless of communication or broadcasting, according to the location or the requirements (e.g. low price, power saving) of users to transmit a certain volume of data at requests to communication peer whenever users' like [1]-[3].

The new generation mobile communication (NeGeMo) system, is such a functional integration of mobile communication systems including cellular and high-speed mobile wireless access systems, non-wireless systems, and broadcasting systems to enhance inter-system compatibility. In the NeGeMo system, a user needs to have only one terminal to achieve multiple communication systems. The most promising technology to achieve such terminals is software defined radio (SDR) technology, which allows users to switch communication and broadcasting systems by changing software alone. A user therefore has to carry only one terminal to achieve communication and broadband systems of user's choice.

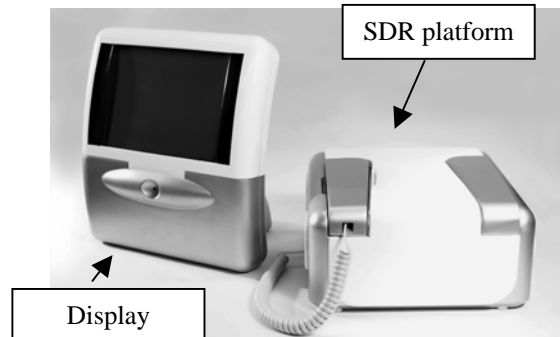

Fig. 1 Photograph of SDR platform.

NICT has developed an SDR platform that consists of FPGA board, CPU boards, and RF boards. That size is 20 cm wide, 20 cm deep, and 8 cm high. For the SDR platform, users firstly install their favorite software that can realize communication systems by using compact flash card. Then the software is stored to the memory in the platform. After that, users can customize a menu that shows users' priority for the communication systems installed in the memory. On the platform, software packages for W-CDMA, IEEE802.11a/b, and digital terrestrial broadcasting have been developed, because these communication and broadcasting systems currently exist as the systems that need high-speed signal processing. Each software package consists of physical layer part (for communication and broadcasting systems) and MAC/DLC layer part, IP layer part, and application part (for communication system). In this paper, the details of SDR platform and software are introduced. Then, the volume of each software package for FPGAs and CPUs is shown and the relationship between cognitive radio and this prototype is discussed. Moreover, the requirements and image of cognitive radio is also summarized.

## II. SDR PLATFORM

Figures 1 and 2 show the SDR platform that consists of FPGA board, CPU board, and RF boards. Figure 3 and Table 1 show the configuration. On the FPGA board, 4 FPGAs with 1152 pins are prepared. Two FPGAs process a physical layer for communication and broadcasting systems and connect with two analog-digital converters (ADCs), two digital-analog converters (DAC), and RF control units (RF cnt.). The RF control unit is an interface to control an RF board, e.g. AGC, AFC, and channel selection. On the CPU board, two CPUs are prepared and a CPU controls system selection algorithm and TCP/IP stack. Another controls MAC layer protocol. RF boards convert baseband signal to adequate frequency band. In the platform, 150-800MHz (receipt), 1.9-2.4 GHz and 5-5.3 GHz bands (transmission and receipt) are available.

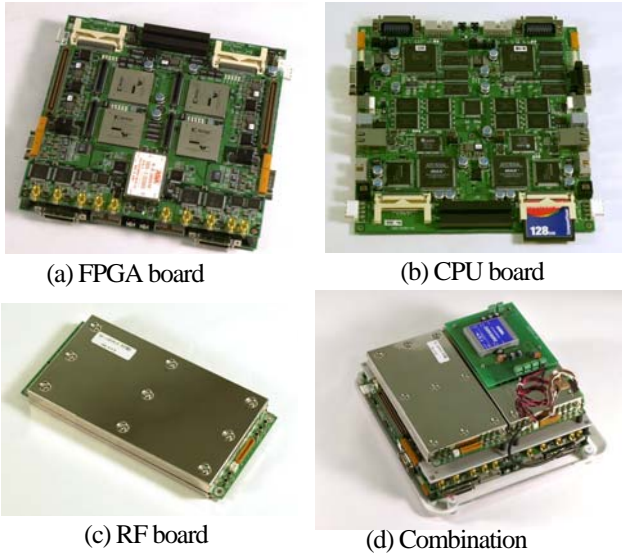

Fig. 2 SDR platform.

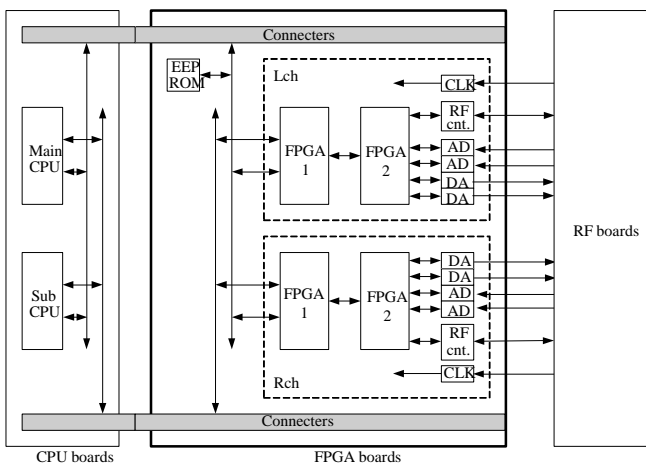

Fig. 3 Configuration of SDR platform.

### III. INSTALLATION OF SOFTWARE

In order to realize users' favorite communication systems by changing software packages, we must consider how to install the packages to the SDR platform. The followings are the procedures. The SDR platform has control software shown in Fig. 4 worked on an operation system:  $\mu$ ITRON. The control software helps to install software from compact flash (CF) card to Flash ROM in the SDR platform and gives priorities of communication systems to the SDR platform. From the flash ROM, the software is downloaded to the FPGAs or CPUs to realize communication systems by following the priorities set by the users.

When the control software is booted, the software checks all of information stored in the RF boards. The information is the ability of each RF board that is bandwidth or frequency range and so on. Then the software shows the information of RF board (see the mark 6 in Fig. 3). Next users insert CF card stored new software to the SDR terminal and see the kinds of software package of communication systems in the CF card (see the mark 1). Users select their favorite software and click the button of install (see the mark 2). The install condition will be seen in the flash ROM, the software that has already been implemented can be seen in the mark 3. Then users see the information of

Table 1 Requirement of FPGA, CPU, and RF boards.

Item	Requirement
FPGA board	
ADC	2ch/170 Msps/12bit/0dBm input
DAC	2ch/500 Msps/12bit/0dBm output
FPGA	Xilinx XC2V4000,6000,8000 (selectable)
IF to RF board	Analog in (2ch)/Analog out(3ch)/Cont(5bit)
External clk I/F	Input 5M-66MHz, 0dBm 2,4,8,16 times clk generate automatically
External output	CPU-IF (Max 80Mbyte/s) External output(Max 600Mbyte/s)
CPU board	
CPU	430 MIPS(240MHz) $\times$ 2
OS	$\mu$ -ITRON (PrKERNEL v 4)
I/O	Compact Flash, RS232C,USB,Ethernet/JTAG
RF boards	5 GHz band + 2 GHz band +VUHF board

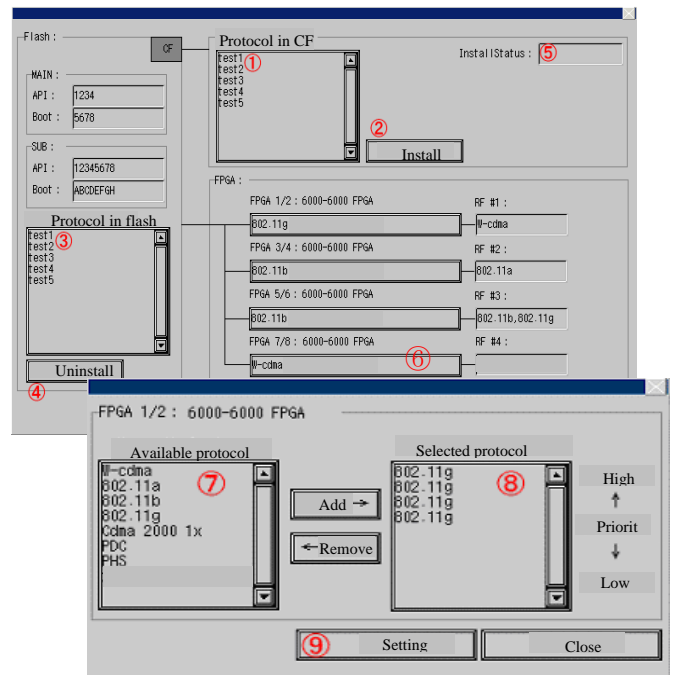

Fig. 4 Software installer.

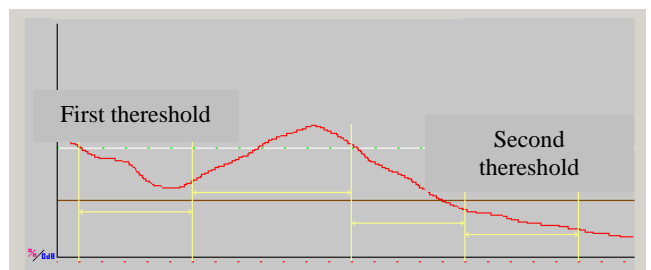

Fig. 5 Communication system selection technique.

RF board shown in the mark 6 and set their favorite priorities. To set the priorities, users must click pull-down menu beside the information of RF board. In the menu as shown in Fig. 4, users must decide the priorities from list of the available communication systems. Finally all of settings are ready.

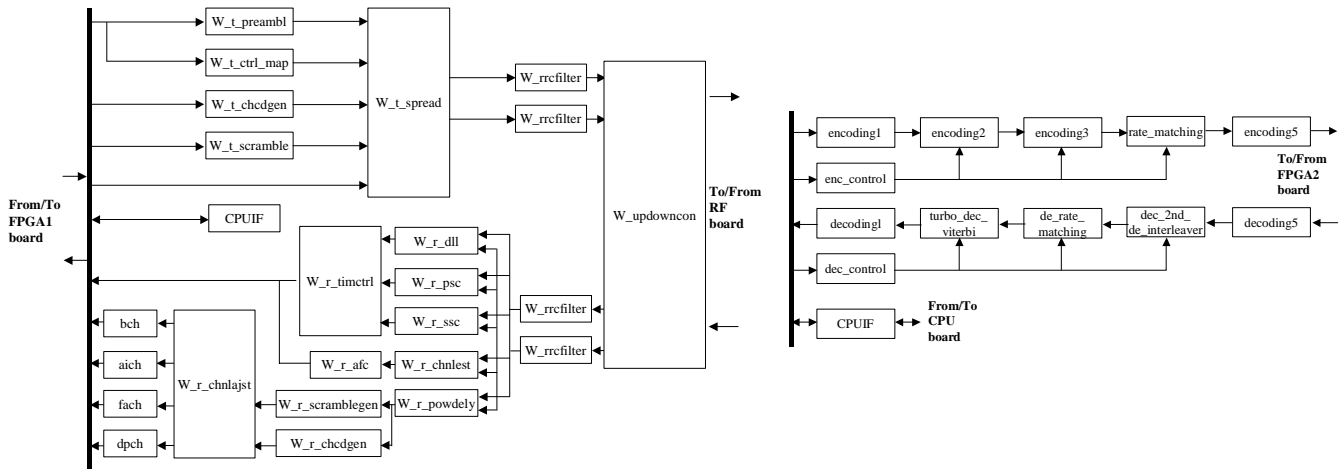

Fig. 6 Configuration of FPGA software for W-CDMA (left – FPGA2 and right – FPGA1).

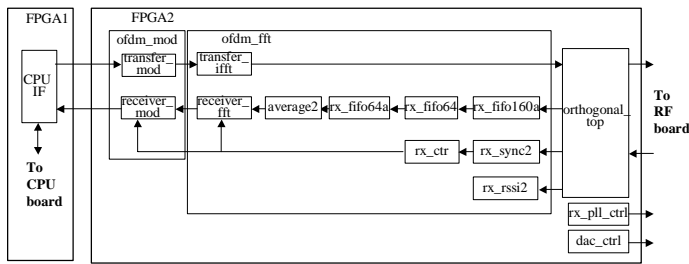

Fig. 7 Configuration of FPGA software for IEEE802.11a.

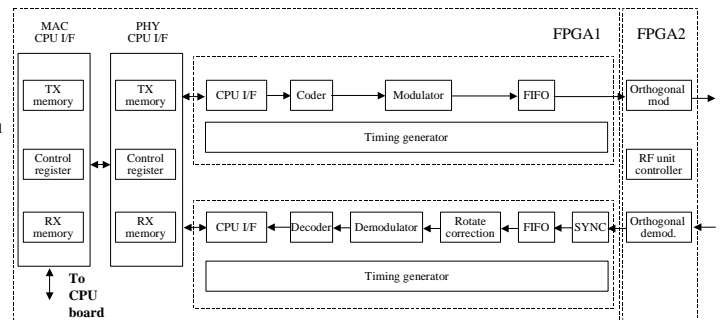

Fig. 8 Configuration of FPGA software for IEEE802.11b.

#### IV. CHAGE OF SOFTWARE

The software radio prototype can change its communication system in accordance with the circumstance of the user who has the prototype. Once user execute an installed software to realize one system, the prototype always checks system parameters, e.g. RSSI, BER, FER, throughput, and so on. When the system parameters degrades and us slightly below the first threshold level as shown in Fig. 5, the prototype starts to look for new communication systems by the order of the priority of users and decides the handover communication system. At this moment, there should be no change. In case of going below the second threshold, there should be a change. The reference [3] proposes this technique using the two thresholds to change communication systems. The optimum of this technique gives rooms for further study points. This type of switching technique is worth for further discussion. To understand the surroundings of users and utilize the results for the selection of adequate communication systems connected shows that this prototype realizes a cognitive radio.

#### V. CONFIGURATION OF SOFTWARE

On the platform, software packages for W-CDMA, IEEE802.11a/b, and digital terrestrial broadcasting (13 segments Japanese terrestrial HDTV, 64QAM-OFDM, information rates 21.47Mbps) have been developed. Figures 6-9 show the configurations of software packages (two FPGAs) for W-CDMA, IEEE802.11a/b, and digital

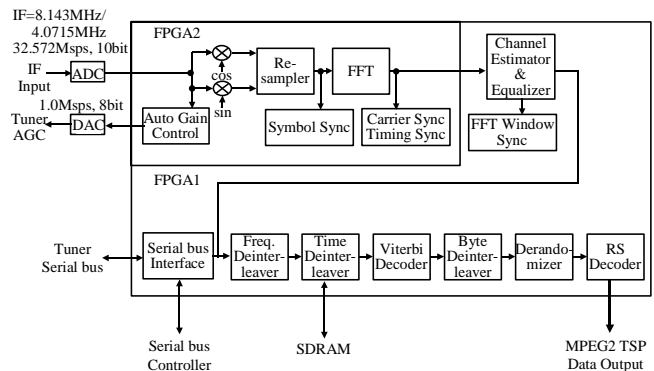

Fig. 9 Configuration of software for digital terrestrial TV.

terrestrial TV. Tables 2-5 show the volume of each software (slices) for two FPGAs, respectively. As for W-CDMA physical layer, 43577 and 28691 slices are needed for FPGA 1 and FPGA2, respectively. As for IEEE802.11a/b physical layer, 655/10146 and 21966/2421 slices are needed for FPGA1 and 2, respectively. 15996 and 23798 slices are needed for two FPGAs to realize digital terrestrial TV (13 segment HDTV). For example, in the case of Xilinx Virtex2 series FPGA, the number of slices in a XC2V6000 that has 600 million system gates is 33792. From these tables, we have only to prepare at two FPGAs that are two XC2V6000 to realize all communication and broadcasting systems that needs high-signal-processing-power. For other software is shown in Table 6.

Table 2 Number of slices used in W-CDMA software.

Function	Name of block	Slices
CPU interface	cpu if	5165
CRC(TX)	encoding_1	406
Turbo/convolutional encoding	encoding_2	2605
First interleaver	encoding_3	364
Rate matching (TX)	rate_maching	1827
Second interleaver	encoding_5	975
Control signal (TX)	enc_control	495
Rate maching (RX)	de_rate_matching	365
Second de-interleaver	dec_2nd_de_interleaver	101
Control signal (RX)	dec_control	5533
CRC(RX)	decoding_1	297
First de-interleaver	decoding_5	300
Turbo decoding	turbo_dec	22188
Viterbi decoding	viterbi	2956
Total (FPGA1)		43577

Function	Name of block(number)	Slices
CPU interface	cpu if	256
Orthogonal modulator	w_updowncnvt	188
IQ filter (TX)	w_rrcfilter(2)	2732
IQ Filter (RX)	w_rrcfilter(2)	4388
Timing control	w_timctrl	69
Channelization code gen (TX)	w_t_chcdgen	794
Mapping of control signal	w_t_ctrl_map	
Preamble gen.(TX)	w_t_preambl	
Scramble code gen.(TX)	w_t_sccdgen	
Spread (TX)	w_t_spread	
Measure power delay profile	w_r_powdely	
DLL	w_r_dll	2742
Synchronization	w_r_psc	1851
	w_r_ssc	2677
AFC	w_r_afc	939
Channel estimation	w_r_chnlest	3414
Scramble code gen.(RX)	w_r_scramblegen	42
Channelization code gen (RX)	w_r_chcdgen	537
Channel compensation	w_r_chnlajst(4)	2616
Data extranction	bch	852
	aich	222
	fach	944
	dpch	944
Total (FPGA2)		28691

Table 3 Number of slices used in IEEE802.11a software.

Function	Name of block (number)	Slices
<b>FPGA 1</b>		
CPU interface	cpu_if	655
<b>FPGA2</b>		
OFDM first modem.	ofdm_top	
First mod (TX)	transfer_mod	429
First demod (RX)	receiver_mod	2943
OFDM second modem	ofdm_fft	
Second mod (TX)	transfer_ifft	453
Second demod (RX)	receiver_fft	4017
Control (RX)	rx_ctr	35
Synchronization (RX)	rx_sync2	6221
RSSI measurement	rx_rssi2	496
RX FIFO	rx_fifo160a	28
	rx_fifo64	25
	rx_fifo64a	27
	average2	30
PLL Control	rx_pll_ctrl	48
DAC Control	dac_ctrl	80
Orthogonal modem	orthogonal_top	7134
Total (FPGA2)		21966

Table 4 Number of slices used in IEEE802.11b software.

Block	Contents	slices
FPGA1	MAC CPU I/F	
	TX memory	1151
	RX memory	1428
	Control register	570
	PHY CPU I/F	
	TX memory	313
	RX memory	584
	Control register	863
	TX Block	
	CPU I/F	285
	Coder	141
	Modulator	78
	FIFO	165
	RX Block	
	CPU I/F	206
	Decoder	107
	Demodulator	95
	Rotate correction	149
	FIFO	160
	SYNC	2352
Timing generator	61	
Total (FPGA1)	10146	
FPGA2	TX orthogonal mod	760
	TX orthogonal demod	1047
	RF unit controller	321
	Total (FPGA2)	2421
Total		12567

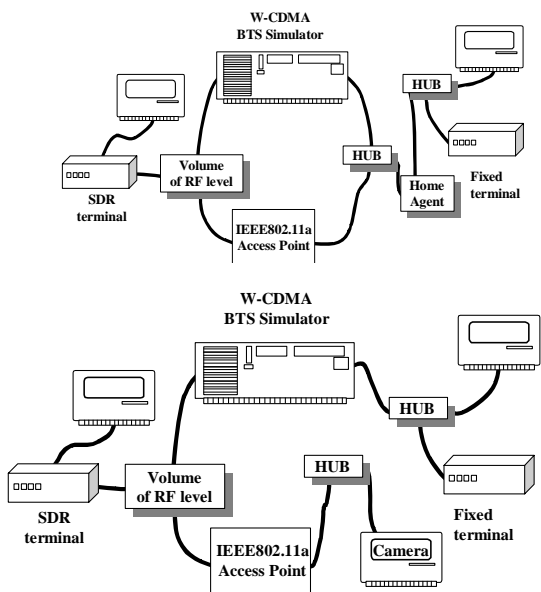

Fig. 10 Two types of demonstration.

VI. DEMONSTRATION OF THE PROTOTYPE

By using the developed SDR terminal, the demonstration shown in Fig. 10 can be realized. One is system “selection” demonstration. First of all, SDR terminal connects with a W-CDMA BTS simulator (Base station) and communicates with the other people in a wired network. Then, by changing the volume, the input signal level from BTS to SDR terminal decreases and the input signal level from wireless LAN access point increases. In this case, the SDR terminal automatically installs wireless LAN software and continues to communicate with the people in a wired network.

Table 5 Number of slices used in digital terrestrial TV software.

Block	Contents	slices
FPGA1	Auto Gain Control Resampler	2244
	Symbol Sync	5635
	FFT	2753
	Carrier Sync Timing Sync	5364
	Total (FPGA1)	15996
FPGA2	FFT Window Sync	2806
	Channel Estimator Equalizer	5100
	Freq. Deinterleaver	498
	Time Deinterleaver	4617
	Viterbi Decoder	7302
	Byte Deinterleaver	559
	Derandomizer	79
	RS Decoder	2699
	Serial bus Interface	138
	Total (FPGA2)	23798
	Total	39794

Table 6 Volume of software.

Volume	Volume (byte)
CPU-OS	210k(Main-CPU) / 193k (sub-CPU)
System Selection/ TCP-IP	583k(Main-CPU)/ 219k(sub-CPU)
W-CDMA	2.214M(sub-CPU) 3.217M(FPGA1)/2.668M(FPGA2)
IEEE802.11a/b	168k(CPU)/1.192M(FPGA1)/2.668M(FPGA2)
Digital terrestrial TV	2.668M(FPGA1 and FPGA2)

Second is system “multiplexing” demonstration. First of all, SDR terminal connects with W-CDMA BTS simulator (Base station) and communicate with the other people in a wired network. Then, by changing the volume, the input signal level from wireless LAN access point increases. In this case, the SDR terminal receives both W-CDMA and wireless LAN signals.

### VII. COGNITIVE RADIO

Cognitive radio is a radio or system that senses, and is aware of, its operational environment and can dynamically and autonomously adjust its radio operating parameters accordingly by collaborating wireless and wired networks. As results of sensing, when some vacant and available frequencies/time slots exist in a system, users temporally utilize the frequencies and time slots. When users would like to use several communication systems and some vacant and available frequencies and time slots exist over some communication systems, users temporally utilize the frequencies and time slots.

When cognitive radio is realized, the radio equipment must be amulti-purpose, multi-band, and multi-service equipment on the frequency bands from VUHF band to 6GHz band. In the era, radio equipment is categorized into three as shown in Table 7.

Class A radio equipment – the equipment can operate all kind of communication systems that use frequency bands less than 6GHz.

Class B radio equipment – the equipment can operate all kind of communication systems that use frequency bands from 800 MHz to 6GHz.

Class C radio equipment - the equipment can operate all kind of communication systems that use frequency bands from 3GHz to 6GHz.

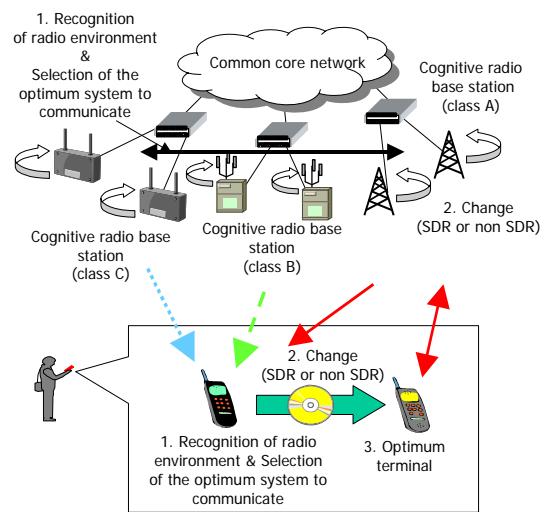
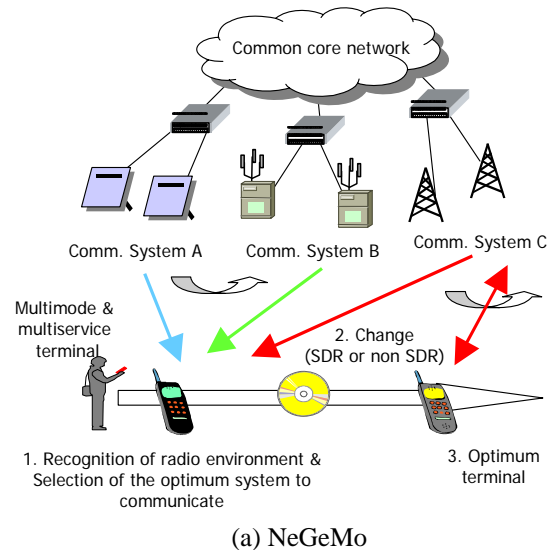

Fig. 11 Relationship between NeGeMo and cognitive radio base NeGeMo.

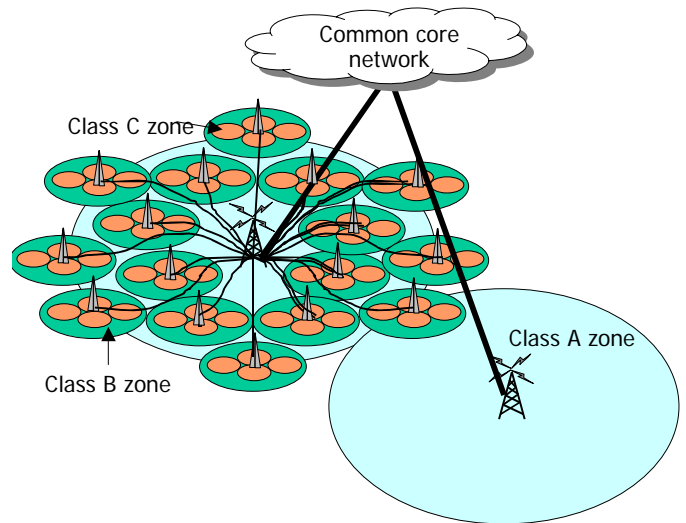

Fig. 12 An example of the allocation of base stations.

Table 7 Category of radio equipment in the era of cognitive radio.

		Class A radio equipment									Class B radio equipment					Class C radio equipment		
		A BS 1	A BS 2	A BS 3	A BS 4	A BS 5	A BS 6	A BS 7	A BS 8	A MS	B BS 1	B BS 2	B BS 3	B BS 4	B MS	C BS 1	C BS 2	C MS
I	(a) freq. < 800M Power > 2W	○	○	○	○													
	(b) freq. < 800M Power ≤ 2W					○	○	○	○	○								
II	(a) 800M ≤ freq. < 3G Power > 500mW	○	○			○	○				○	○						
	(b) 800M ≤ freq. < 3G Power ≤ 500mW			○	○			○	○	○			○	○	○			
III	(a) 3G ≤ freq. Power > 500mW	○		○		○		○			○		○		○			
	(b) 3G ≤ freq. Power ≤ 500mW		○		○		○		○	○		○		○		○	○	

In each category, the radio equipments are categorized into several domains from the viewpoint of transmission power and utilization image (base station ? mobile terminal?).

Figure 11 shows the difference between NeGeMo communication systems and cognitive radio base NeGeMo systems. As for the base station, the NeGeMo communication systems use conventional one. Mobile terminals look for adequate base stations that can be connected and connect with the adequate base stations that can keep user's QoS. On the other hand, in the cognitive radio base NeGeMo systems, each base station is multi-purpose, multi-band, and multi-service. This means that base stations check their surroundings and change the function, and become adequate base stations that reduce interference as low as possible. In this situation, mobile terminals look for adequate base stations that can keep users' QoS and communicate with them.

By using cognitive radio terminal (class 1-3) based on Table 7, the allocation of base stations is also changed. Figure 12 shows an example of the allocation of base stations. The class A base stations cover all over the area where users exist. The area of class A radio equipment is wide and the transmission speed can change easily. The main mission of the class A base station is to connect users even if the transmission rate is low and even if the radio communication environment is worse.

Based on the coverage area, the class B base stations make their communication area. The class B base stations belong to the class A ones. By the same manner, the class C base stations makes their communication area. All base stations include cognitive radio technology. Therefore, the base stations check their circumstance related to usage of frequency band and decide adequate radio communication systems. All of base stations may also make self-organized network when the base stations can not connect with wired backbone network.

### VIII. CONCLUSION

An SDR platform and the software packages that realize communication/broadcasting systems (W-CDMA, IEEE802.11a/b, and digital terrestrial TV) have been developed. The platform can select adequate systems to users by using unique software install algorithm. This paper also showed the adequate volume of FPGAs to realize these systems. This paper also showed the image and requirement of cognitive radio based on the research results. This is the world-first-work to realize third generation mobile communication systems and IEEE802.11 wireless LAN, and digital terrestrial TV. As a further work, multi-band antenna to cover all of the systems must be discussed.

### REFERENCES

- [1] Special Issue on Globalization of Software Radio, IEEE Commun. Mag., Feb. 1999.
- [2] H. Harada, "Software defined radio prototype for W-CDMA and IEEE802.11a wireless LAN," 2004 IEEE 60th Vehicular Technology Conference (VTC2004-Fall), vol. 6, pp. 26-29, Sept. 2004..
- [3] H. Harada, M. Fujise and M. Mizuno, "Multimedia Integrated and Seamless Network by a New Multiservice Terminal, " Proc. IEEE Vehicular Technology Conf. (VTC2001-Fall), vol. 4, pp. 2574-2578, Atlantic City, NJ, U.S.A., Oct., 2001.

# SOFTWARE DEFINED RADIO PROTOTYPE FOR MULTI-MODE AND MULTI-SERVICE RADIO COMMUNICATION SYSTEMS

Hiroshi Harada and Ryuhei Funada  
National Institute of Information and  
Communications Technology (NICT)  
{harada,funada}@nict.go.jp

# Vision for SDR

- Software defined radio (SDR) is one of key technologies to realize next generation (beyond 3G) mobile communication systems from the viewpoints of ....

- Bug fix
- Reduction of industrial waste
- Frequency re-allocation (viewpoint of regulation)
- Coexistence between old and new systems
  - Communication systems on demand

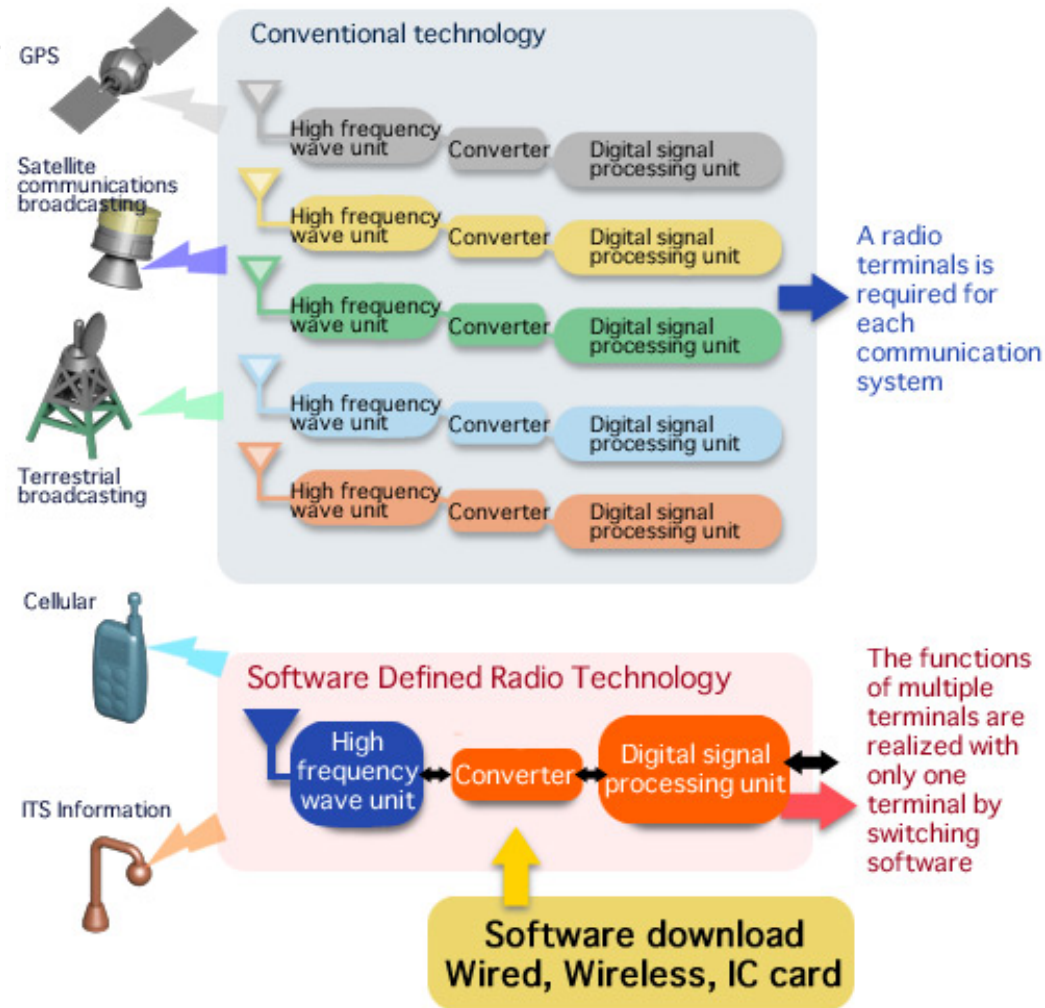



# SDR in next generation mobile (NeGeMO) communication systems

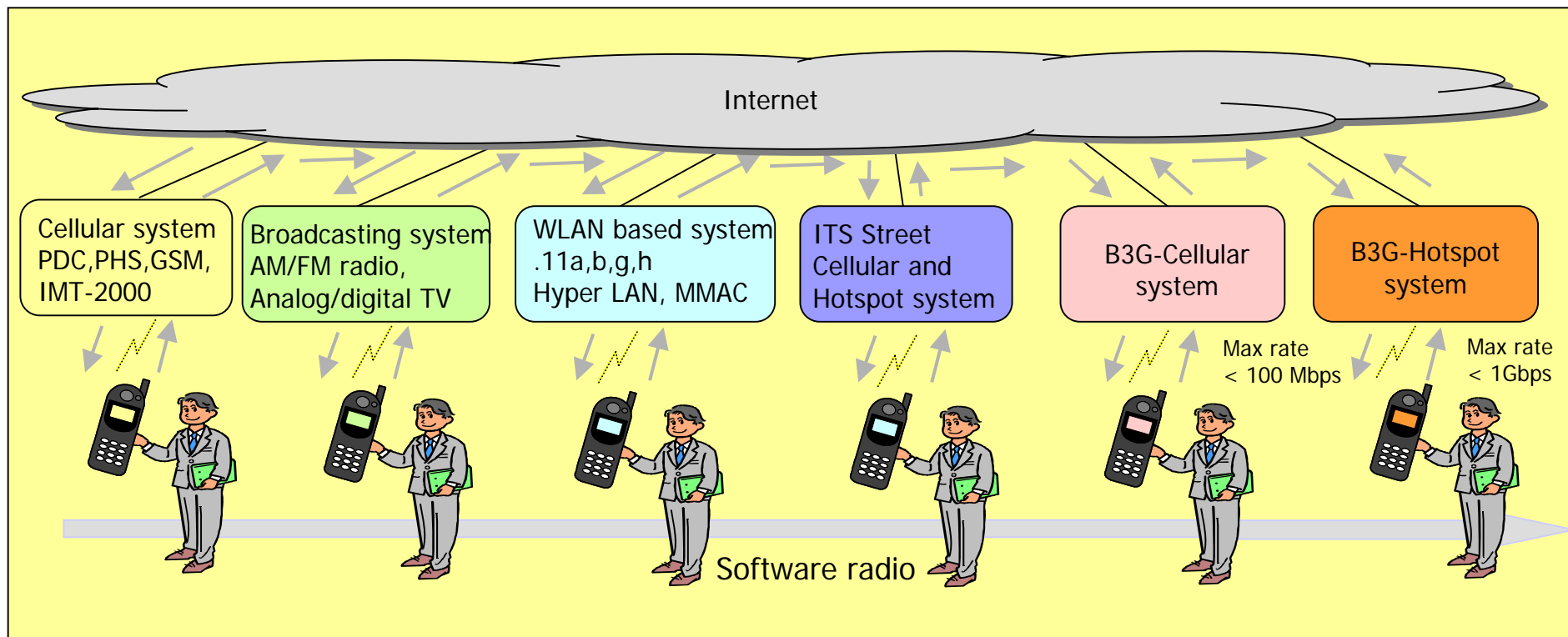

# Required modes for SDR in NGMO era

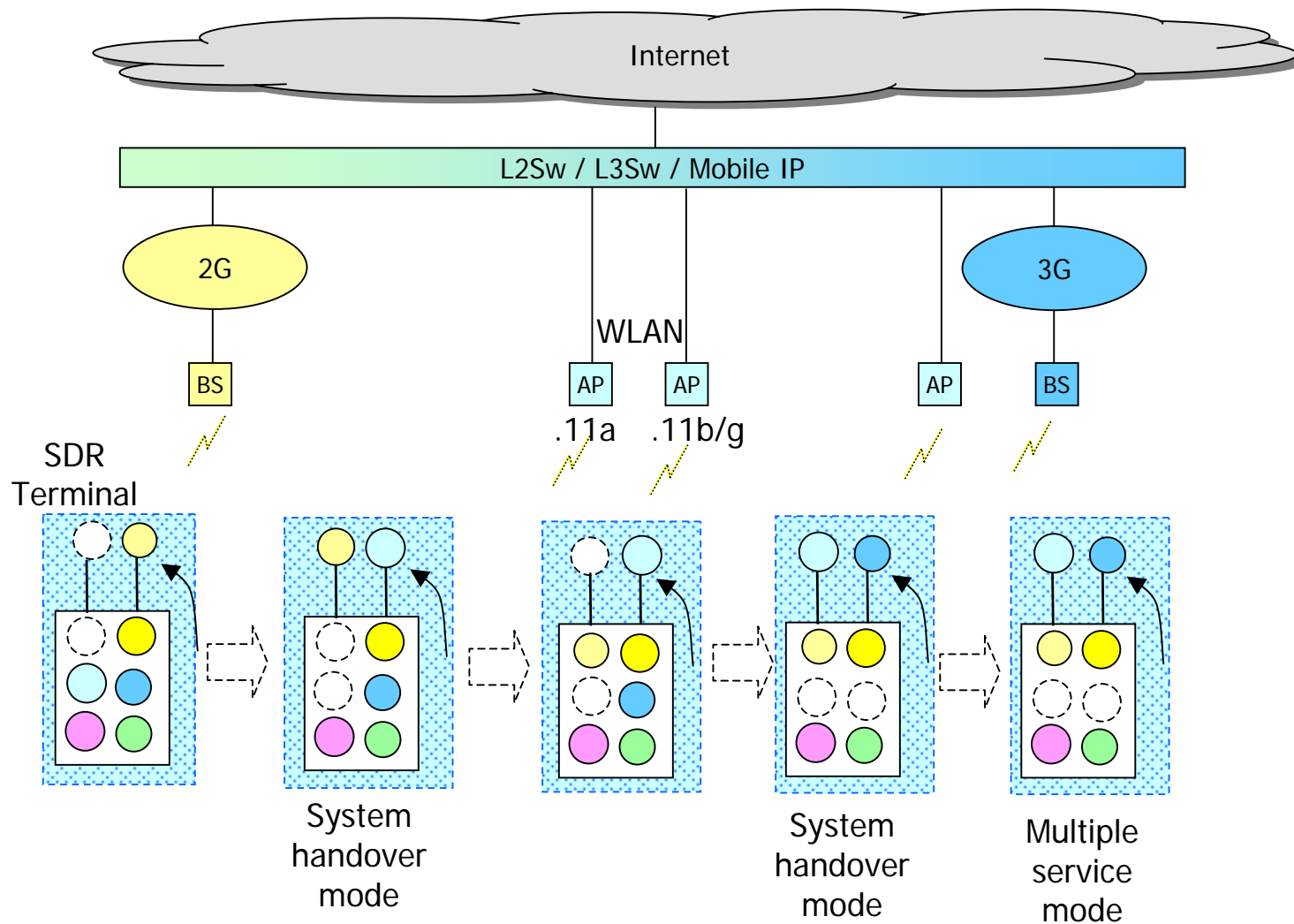

# Requirement to realize SDR in NGMN

- System “selection” (handover) mode
  - Soft handover mode between different systems
  - Hard handover mode between different systems
- System “multiplexing” mode
  - Multiplexing between different systems
  - Multiplexing between same systems
- System “avoidance” mode

# Roadmap for NICT-SDR

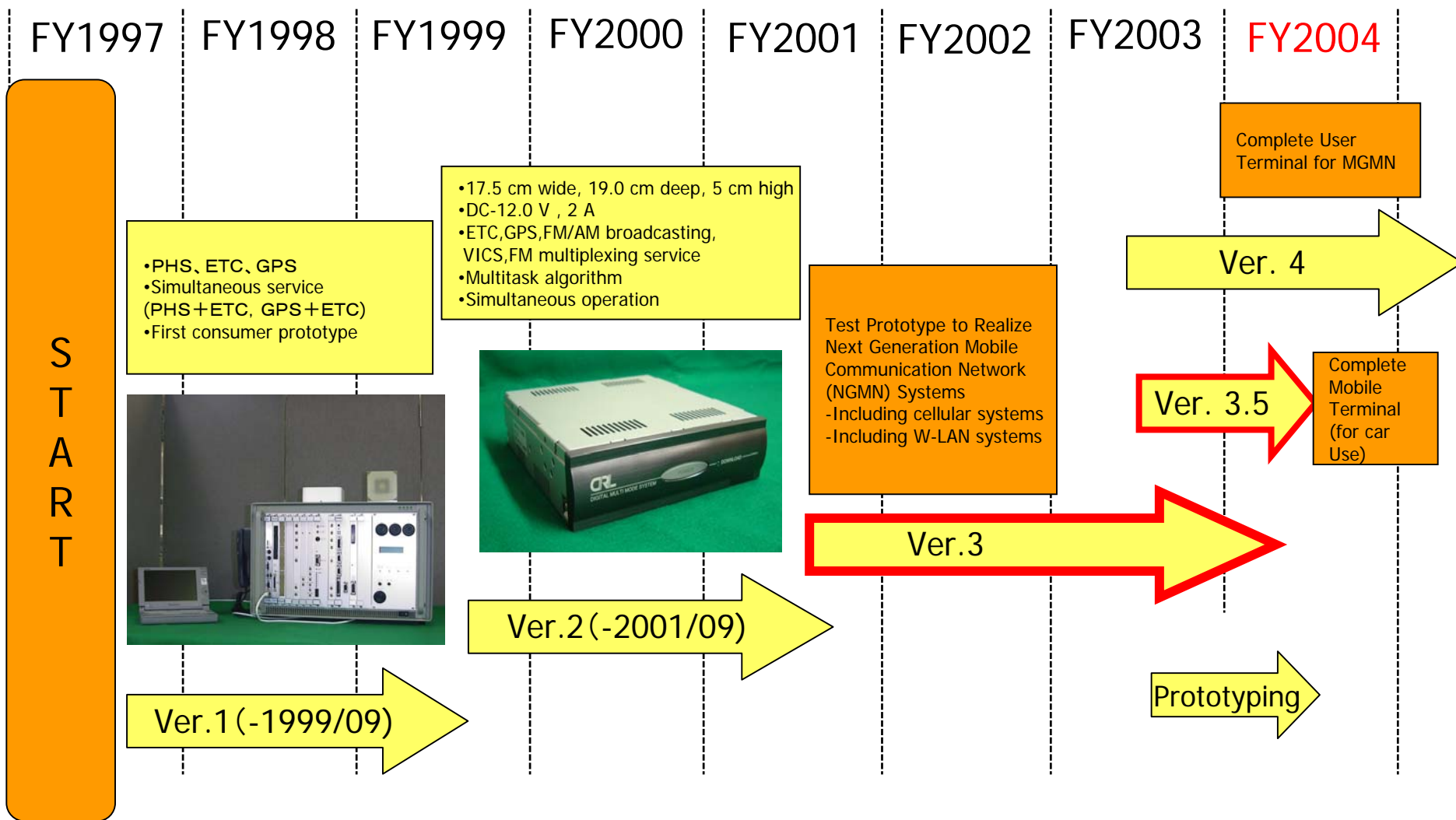

# Development of SDR prototype

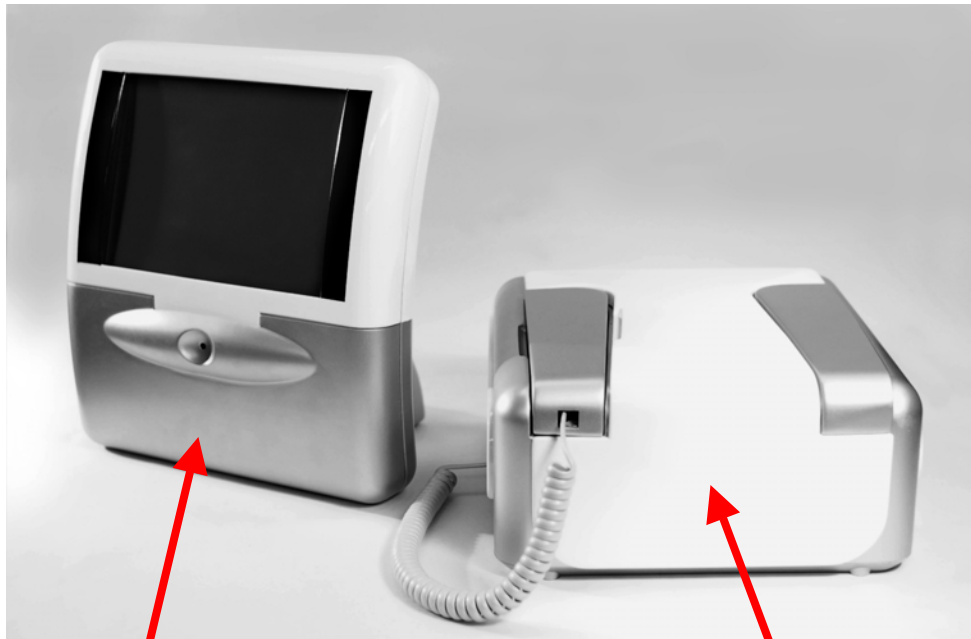

Display part

SDR processing part

- Consists of general-purpose FPGA, CPU, and RF boards
- Software modules for W-CDMA, IEEE802.11a/b, digital terrestrial TV are prepared
- Layer 1,2,and 3 for all systems are completely implemented
- SDR can communicate with W-CDMA BTS and access point for wireless LAN
- Communication systems can be changed manually or automatically

# SDR platform 1

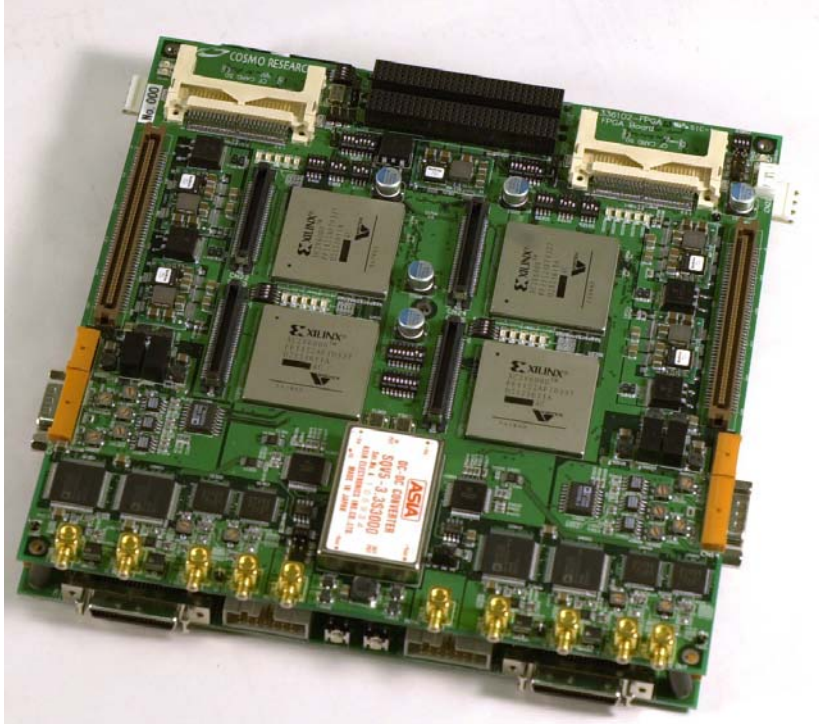

FPGA board

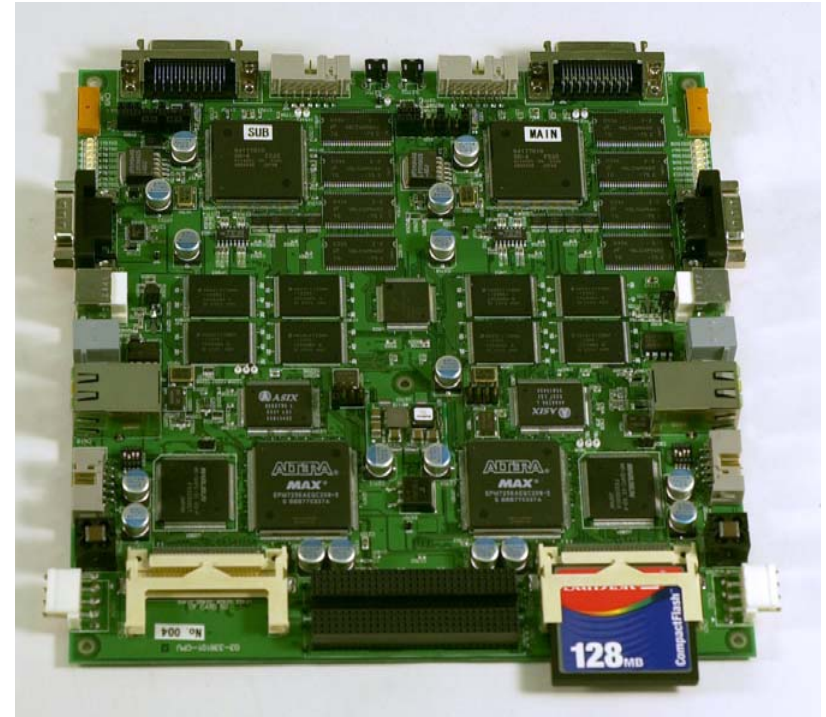

CPU board

# SDR platform 2



RF board



Combination of 3 boards

# Connection between boards

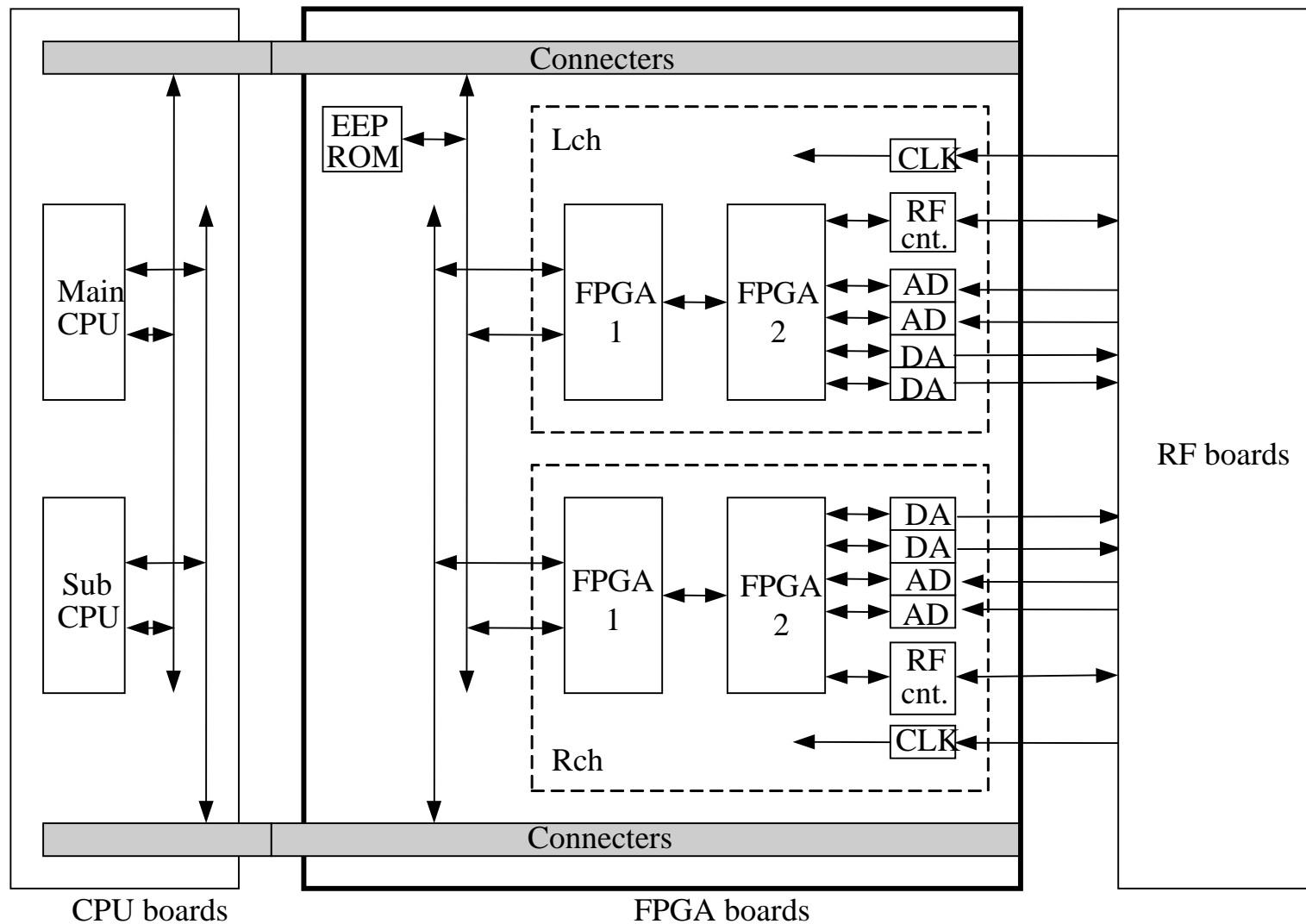



# Requirement of FPGA, CPU, and RF boards

Item	Requirement
FPGA board	
ADC	2ch/170 Msps/12bit/0dBm input
DAC	2ch/500 Msps/12bit/0dBm output
FPGA	Xilinx XC2V4000,6000,8000 (selectable)
IF to RF board	Analog in (2ch)/Analog out(3ch)/Cont(5bit)
External clk I/F	Input 5M-66MHz, 0dBm 2,4,8,16 times clk generate automatically
External output	CPU-IF (Max 80Mbyte/s) External output(Max 600Mbyte/s)
CPU board	
CPU	430 MIPS(240MHz) × 2
OS	μ -ITRON (PrKERNELv4)
I/O	Compact Flash, RS232C,USB,Ethernet/JTAG
RF boards	5 GHz band board + 2 GHz band board+VUHF board

# Characteristics of boards

- Originally designed general-purpose FPGA and CPU boards
  - Boards can be used as common platforms
  - Users can increase the number of FPGA boards.
- Users can activate several communications systems simultaneously
  - Users can activate at least two communication systems by using an FPGA board
  - System selection and system multiplexing can be realized
- Users can use RF boards that decide the interface with FPGA boards
  - Open interface board
  - Requirement of each RF board is written in the board
- CPU boards is operated on the u-ITRON that is embedded operation systems and used for actual terminal
  - Software to manage install, download, system selection , and system multiplexing is operated on the OS

# Installation of software

The screenshot shows a software installation window with the following sections:

- Flash :** A tab labeled "CF" is selected.
- MAIN :** API : 1234, Boot : 5678
- SUB :** API : 12345678, Boot : ABCDEFGH
- Protocol in CF :** A list containing test1, test2, test3, test4, and test5. A red circle with the number 1 is next to test1. An "Install" button is to the right, with a red circle with the number 2 next to it.
- InstallStatus :** A field containing the number 5, with a red circle around it.
- Protocol in flash ROM :** A list containing test1, test2, test3, test4, and test5. A red circle with the number 3 is next to test2. An "Uninstall" button is below the list, with a red circle with the number 4 next to it.
- FPGA :** Four entries for FPGA 1/2, 3/4, 5/6, and 7/8, each with a protocol selected in a dropdown menu:
  - FPGA 1/2 : 6000-6000 FPGA, RF #1 : 802.11g
  - FPGA 3/4 : 6000-6000 FPGA, RF #2 : 802.11b
  - FPGA 5/6 : 6000-6000 FPGA, RF #3 : 802.11b
  - FPGA 7/8 : 6000-6000 FPGA, RF #3 : W-cdma (with a red circle with the number 6 next to it)



The dialog box shows the configuration for "FPGA 1/2 : 6000-6000 FPGA". It has two lists:

- Available protocol :** A list containing W-cdma, 802.11a, 802.11b, 802.11g, Cdma 2000 1x, PDC, and PHS. A red circle with the number 7 is next to 802.11g.
- Selected protocol :** A list containing 802.11g, 802.11g, 802.11g, and 802.11g. A red circle with the number 8 is next to the first 802.11g.

Buttons "Add" and "Remove" are between the lists. To the right of the "Selected protocol" list are "High", "Priority", and "Low" buttons with up and down arrows. At the bottom are "Setting" and "Close" buttons, with a red circle with the number 9 next to "Setting".

# Method to change software

- Two information are used to change software
  - SDR terminal non-oriented information
    - User's favorite transmission rate
    - User's favorite fare to use communication system
    - Reliability of data
  - SDR terminal oriented information
    - RSSI (Received Signal Strength Indicator)
    - BER (Bit Error Rate)
    - FER (Frame Error Rate)
    - When each/all/some of these levels are lower than the first threshold , the SDR terminal starts to look for new systems.
    - When the levels are lower than the second threshold, the SDR terminal changes communication systems by changing software

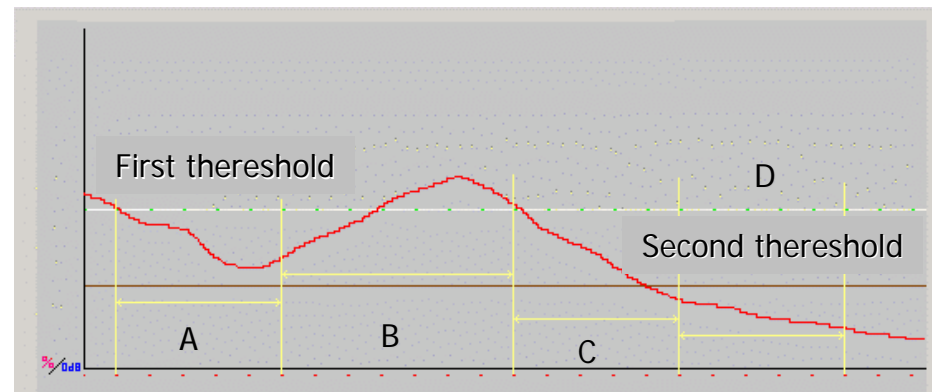

# Prepared software

- To realize seamless communication between cellular communication systems, wireless LAN systems, and broadcasting systems
  - Cellular systems – W-CDMA system
  - Wireless LAN systems – IEEE802.11a/b system
    - Connected with actual BTS simulator of W-CDMA
  - Digital terrestrial TV
- Two kinds of software units
  - FPGA : PHY-Layer
  - CPU managed by uITRON : MAC-Layer, TCP/IP stack, and VoIP, control software
  - Software of L1, L2, and L3 software has been prepared
- Control software
  - Install software from Compact Flash card to SDR terminal
  - Download the software manually
  - Download software adequate for the user that have the terminal automatically by checking the circumstance around the terminal
- Application
  - Video conference
  - VoIP based voice communication

# Volume of software

Items	Volume (Byte)
CPU-OS	210 kByte (Main-CPU) 193 kByte (sub-CPU)
System selection/ TCP-IP	583 kByte (Main-CPU) 219 kByte (sub-CPU)
W-CDMA	2.2414 MByte (sub-CPU) 3.217 MByte / 43577 slices (FPGA1) 2.688 Mbyte / 28691 slices (FPGA2)
IEEE802.11a	168 kByte (sub-CPU) 1.192 MByte / 655 slices (FPGA1) 2.688 Mbyte / 21966 slices (FPGA2)
IEEE802.11b	168 kByte (sub-CPU) 1.192 MByte / 10146 slices (FPGA1) 2.688 Mbyte / 2421 slices (FPGA2)
Digital terrestrial TV	3.217 MByte / 23798 slices (FPGA1) 2.688 Mbyte / 15996 slices (FPGA2)

# Number of slices (Xilinx Vertex II)

Feature/Product	XC 2V40	XC 2V80	XC 2V250	XC 2V500	XC 2V1000	XC 2V1500	XC 2V2000	XC 2V3000	XC 2V4000	XC 2V6000	XC 2V8000
<b>EasyPath cost reduction</b>	-	-	-	-	-	-	-	<b>XCE 2V3000</b>	<b>XCE 2V4000</b>	<b>XCE 2V6000</b>	<b>XCE 2V8000</b>
Logic Cells	576	1,152	3,456	6,912	11,520	17,280	24,192	32,256	51,840	76,032	104,882
BRAM (Kbits)	72	144	432	576	720	864	1,008	1,728	2,160	2,592	3,024
18x18 Multipliers	4	8	24	32	40	48	56	96	120	144	168
Digital Clock Management Blocks	4	4	8	8	8	8	8	12	12	12	12
Max Dist. RAM Kb	8	16	48	96	160	240	336	448	720	1,056	1,456
Max Available User I/O	88	120	200	264	432	528	624	720	912	1,104	1,108

  
 Slices 23040 33792 46592

- Number of slices
  - W-CDMA(43577+28691) > Digital terrestrial TV(39794) > IEEE802.11a(21966) > IEEE802.11b(12567)
  - Reason
    - (W-CDMA) Slices for turbo decoder is large
      - The turbo decoder is also possible to use HSDPA
      - If the volume is reduced, the total number of slices also can be reduced.
  - If the number of slices is larger than 75000, all of communication systems and broadcasting systems can be worked by our prototype



# Demonstration1 - system selection -

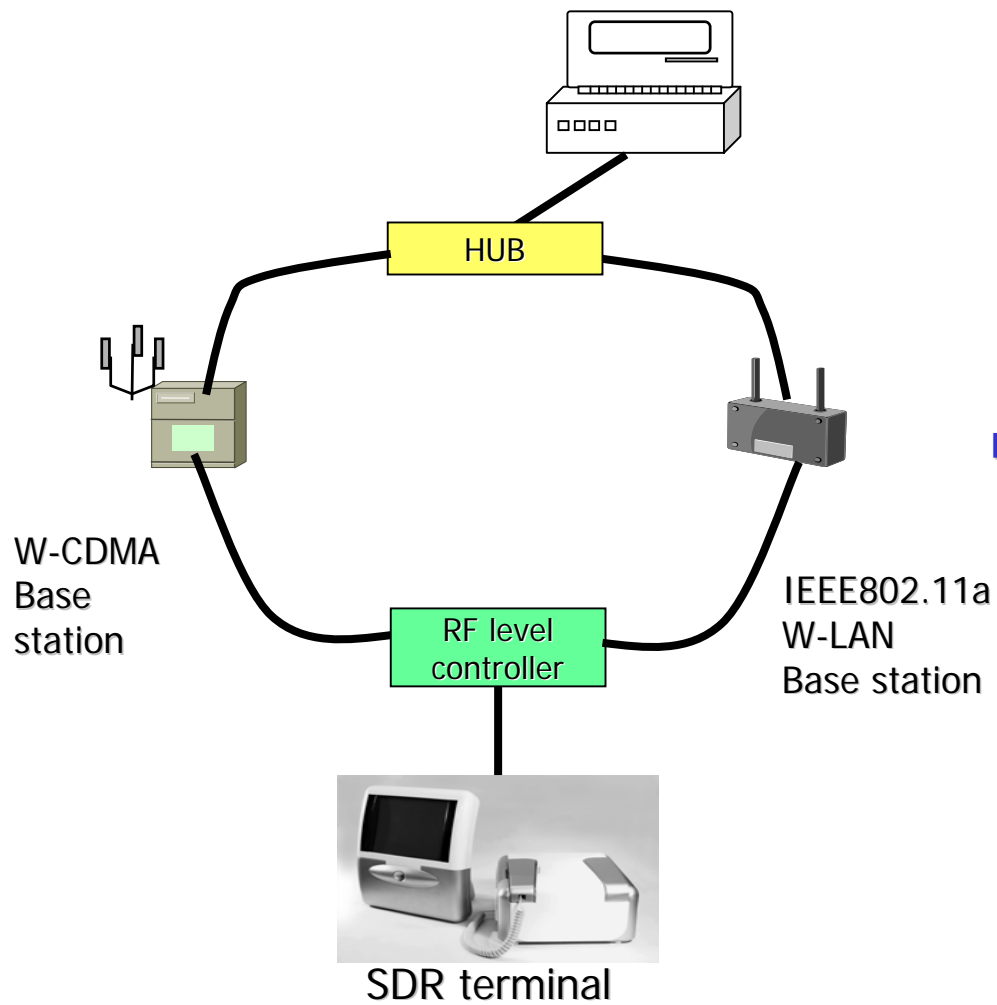

- By changing the RF volume, the input signal level from BTS to SDR terminal decreases and the input signal level from wireless LAN access point increases.
- In this case, the SDR terminal automatically installs wireless LAN software and continues to communicate with the people in a wired network.

# Demonstration2 - system multiplexing -

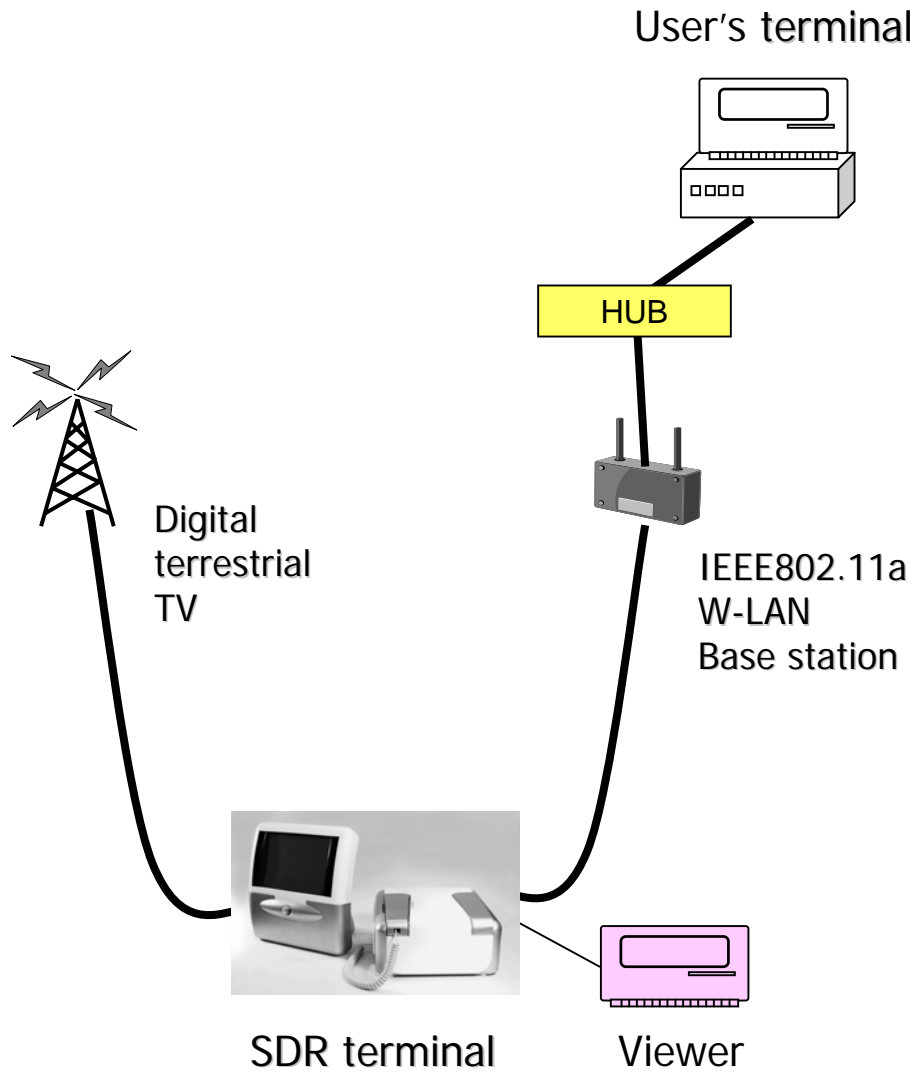

- SDR terminal uses digital terrestrial TV by downloading software
- At the same time, the terminal also downloads Web broadcasting by IEEE802.11b

# Demonstration

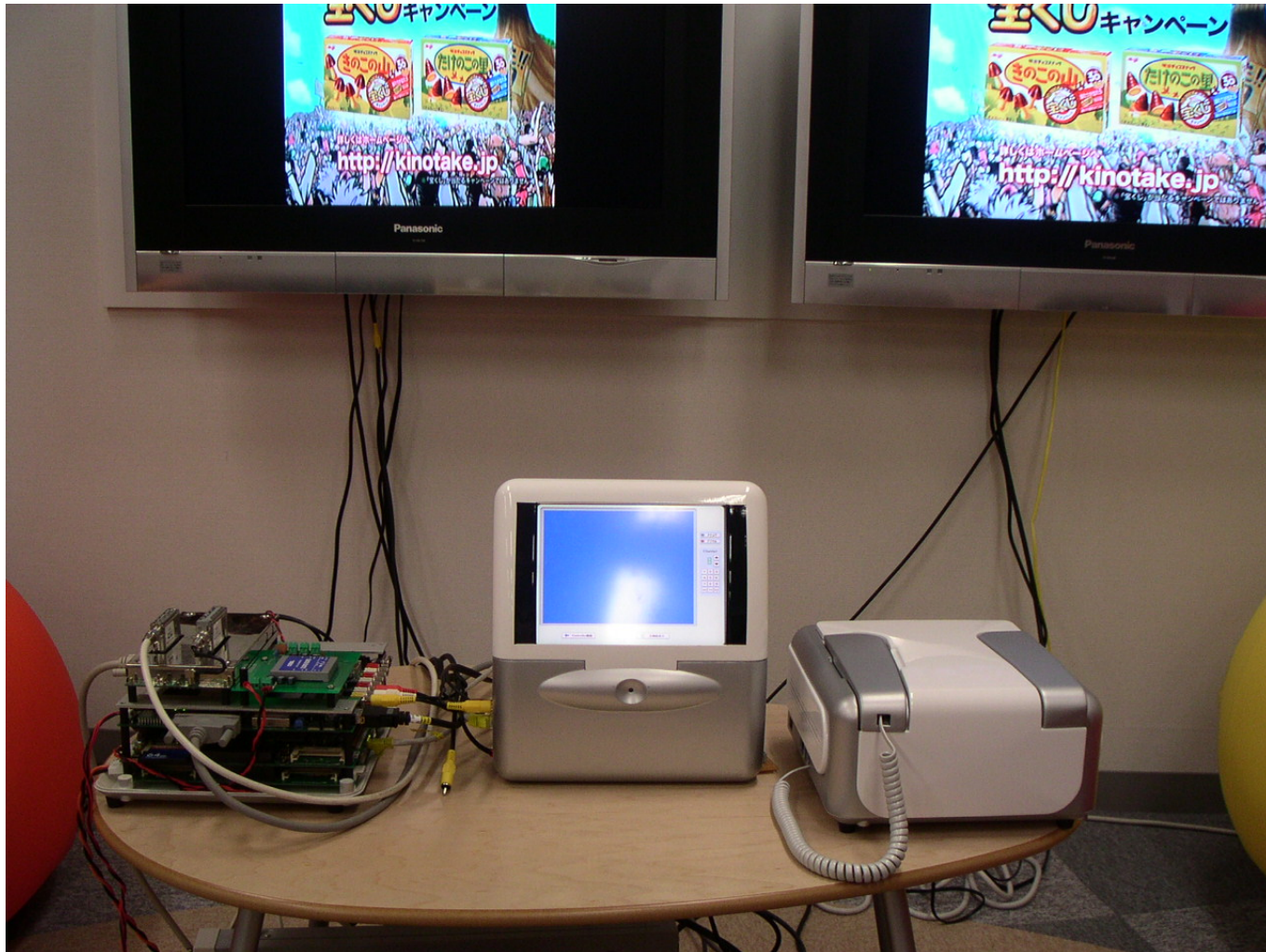

# Final goal

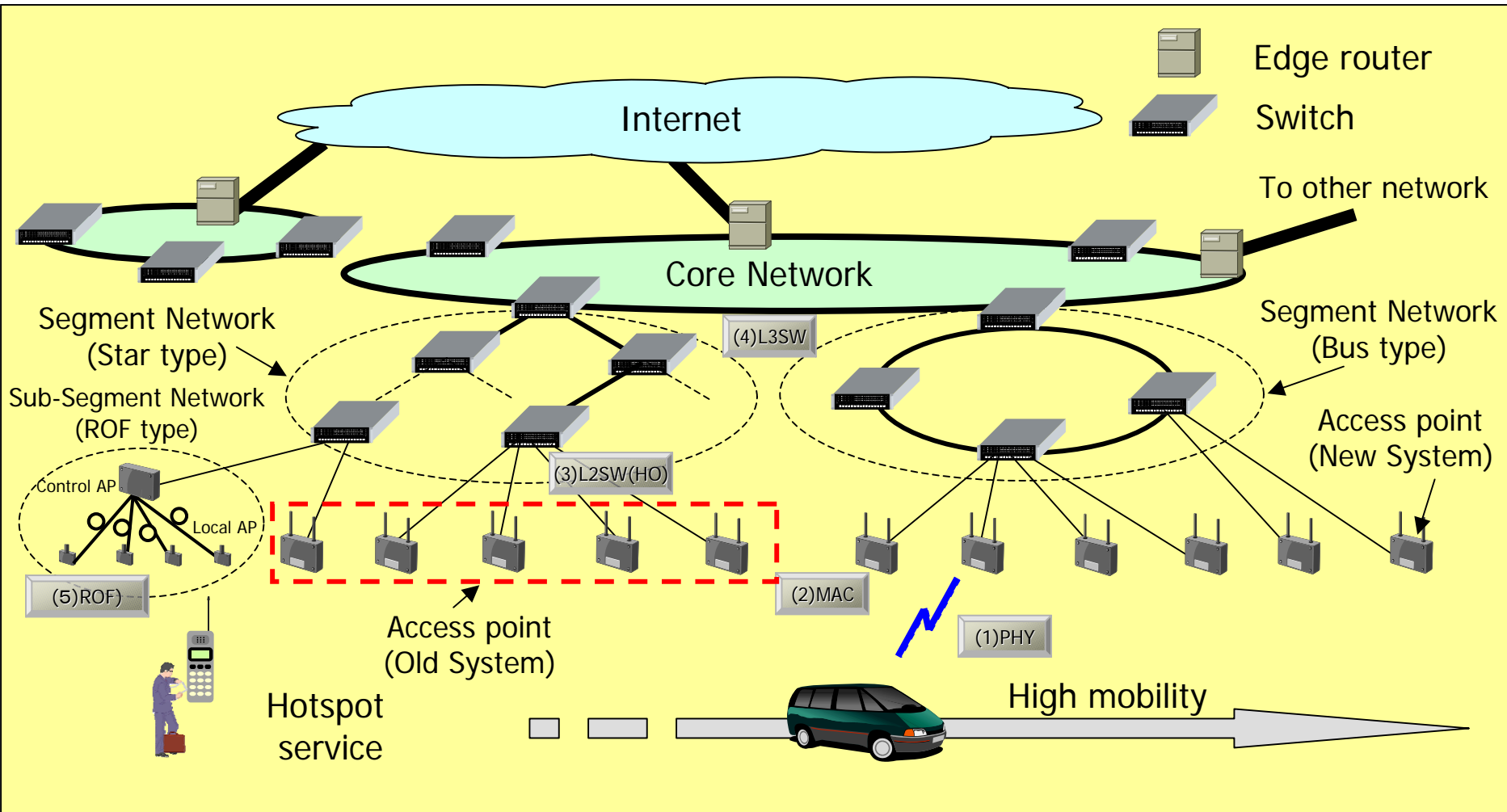

# Future applications toward cognitive radio

## ■ Cognitive radio

- is a radio or system that senses, and is aware of, its operational environment and can dynamically and autonomously adjust its radio operating parameters accordingly by collaborating wireless and wired networks.
- As results of sensing, when some vacant and available frequencies/time slots exist in a system, users temporally utilize the frequencies and time slots.

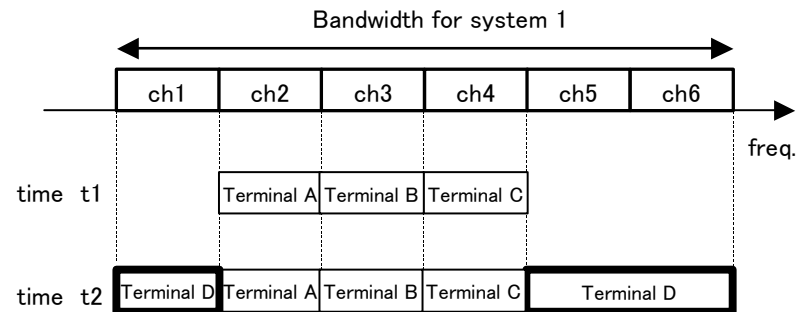

(a) Cognitive radio in a radio communication system

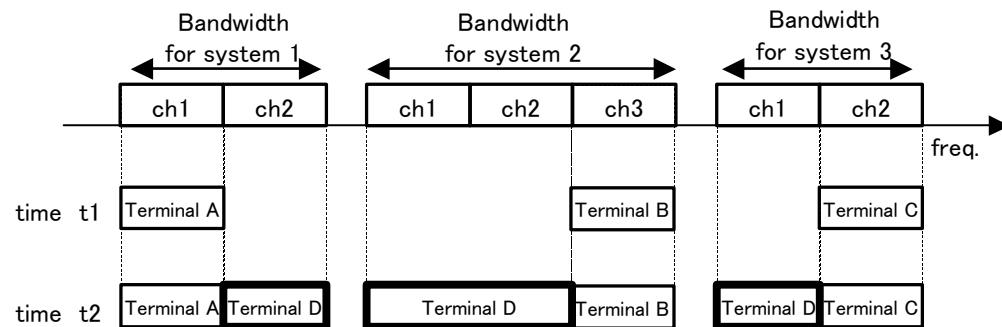

(b) Cognitive radio in several radio communication systems

# Category of radio equipment in the era of cognitive radio

## Class A radio equipment

The equipment can operate all kind of communication systems that use frequency bands less than 6GHz.

## Class B radio equipment

The equipment can operate all kind of communication systems that use frequency bands from 800 MHz to 6GHz.

## Class C radio equipment

The equipment can operate all kind of communication systems that use frequency bands from 3GHz to 6GHz.

# Category of radio equipment in the era of cognitive radio 2

		Class A radio equipment									Class B radio equipment					Class C radio equipment		
		A BS 1	A BS 2	A BS 3	A BS 4	A BS 5	A BS 6	A BS 7	A BS 8	A MS	B BS 1	B BS 2	B BS 3	B BS 4	B MS	C BS 1	C BS 2	C MS
I	(a) freq. < 800M Power > 2W	○	○	○	○													
	(b) freq. < 800M Power ≤ 2W					○	○	○	○	○								
II	(a) 800M ≤ freq. < 3G Power > 500mW	○	○			○	○				○	○						
	(b) 800M ≤ freq. < 3G Power ≤ 500mW			○	○			○	○	○			○	○	○			
III	(a) 3G ≤ freq. Power > 500mW	○		○		○		○			○		○			○		
	(b) 3G ≤ freq. Power ≤ 500mW		○		○		○		○	○		○		○	○		○	○

# Relationship between NeGeMo and cognitive radio based NeGeMo

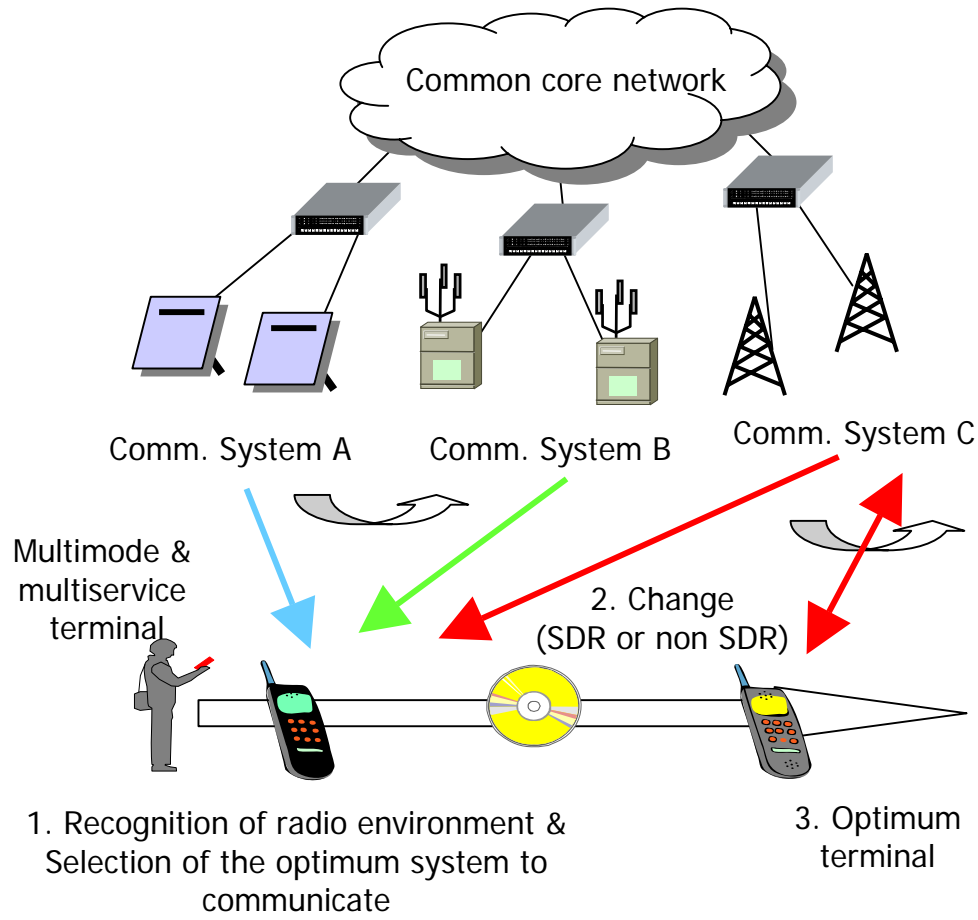

(a) NeGeMo



# Relationship between NeGeMo and cognitive radio based NeGeMo 2

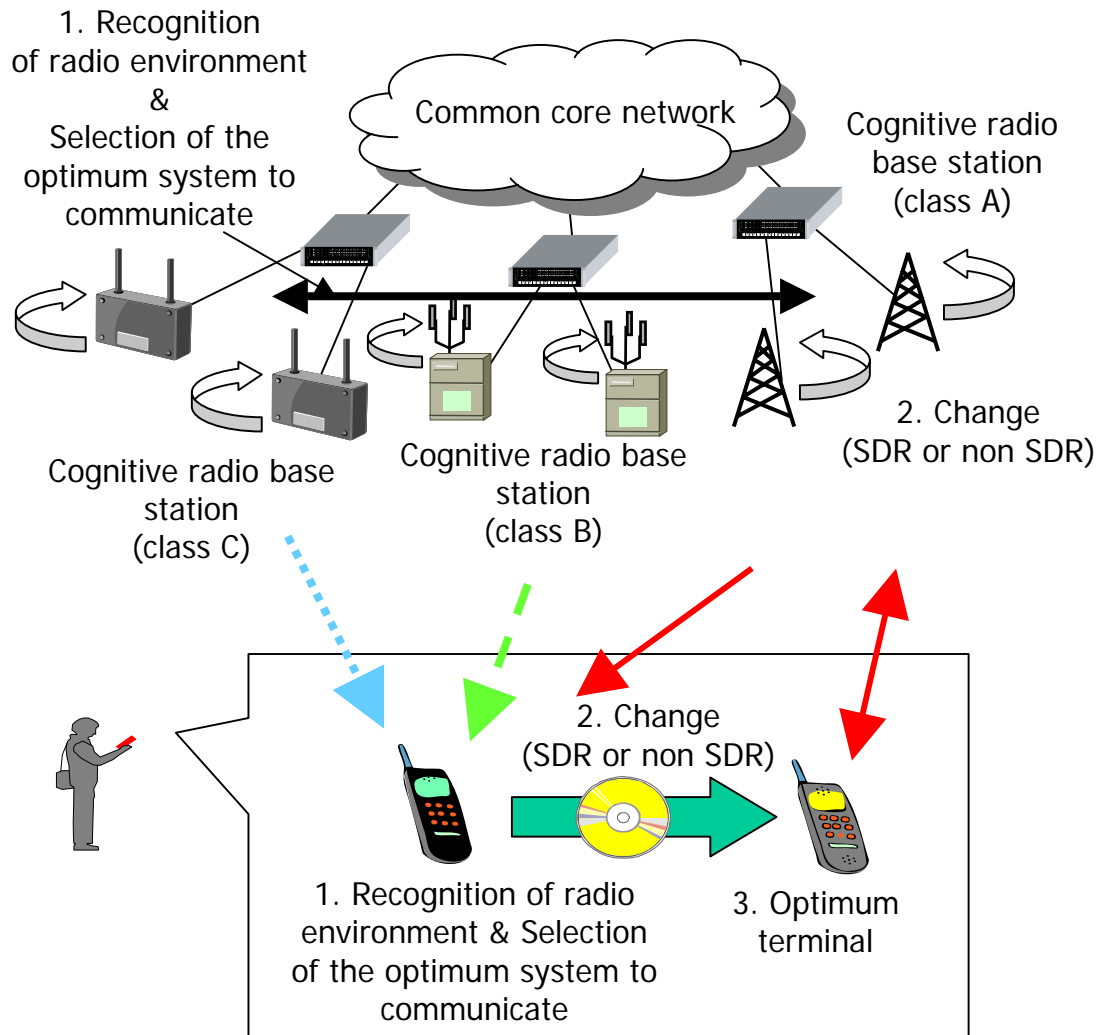

(b) Cognitive radio

# An example of the allocation of cognitive radio base stations

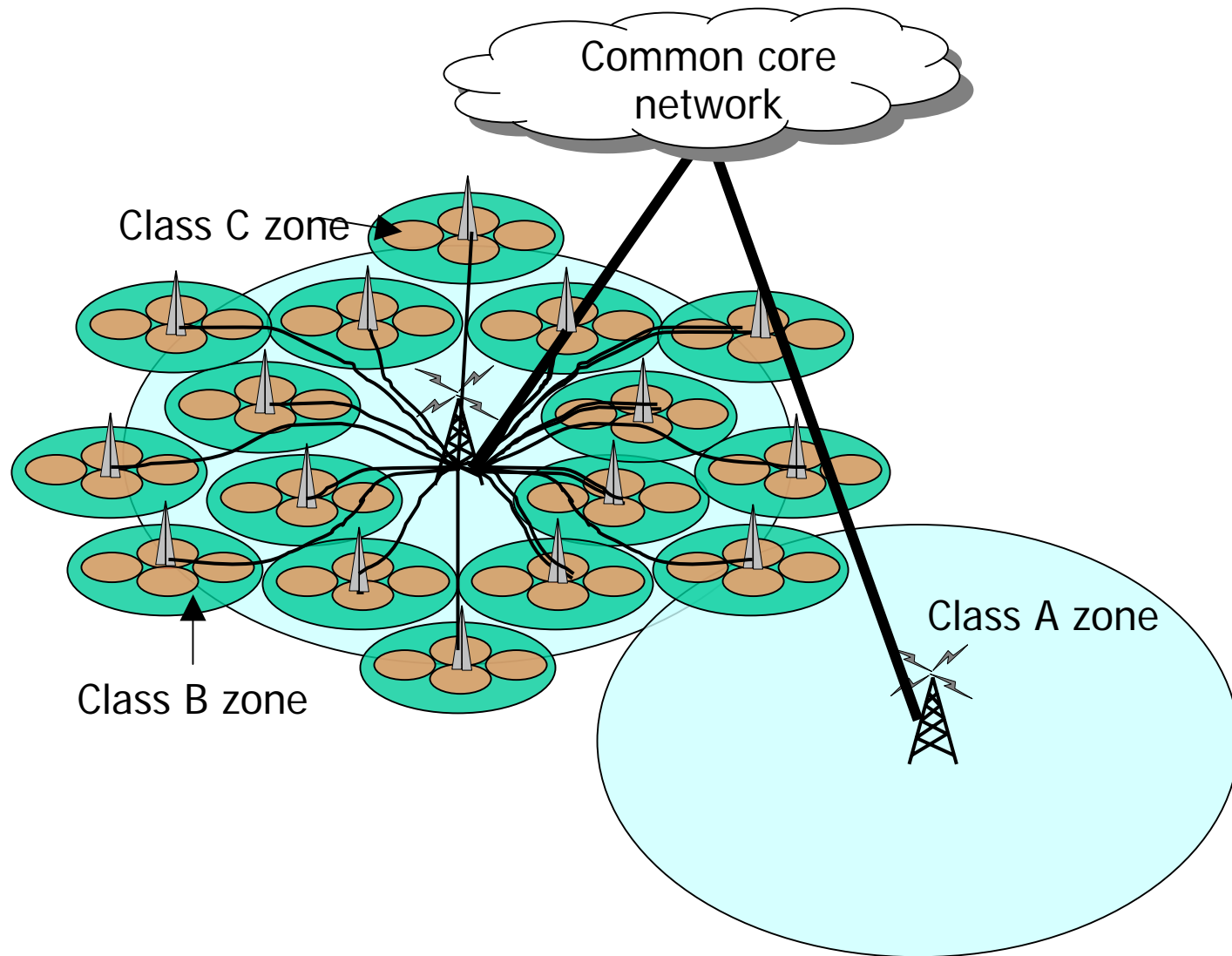

# Conclusions

- Successfully finished to develop software defined radio that can realize 3rd generation cellular radio communication system, wireless LAN, and digital terrestrial TV by changing software
  - W-CDMA, IEEE802.11a/b, digital terrestrial TV can be realized
  - Seamless communication between systems is possible
  - Use common platform
  - System “selection” and “multiplexing” mode can be possible
- Especially in this presentation
  - Detailed information on common platform
  - Detailed information of software
  - Detailed information of software downloader and software switching software
  - Future applications toward cognitive radio
- Future work
  - Reduction of software volume
  - Fast software switching algorithm

# Contact address

Hiroshi Harada, Ph.D.

Leader of Wireless Access Group,  
Yokosuka Radio Communications Research Center  
National Institute of Information and Communications Technology  
(NICT)

E-mail [harada@nict.go.jp](mailto:harada@nict.go.jp)