

DYNAMIC RADIO RESOURCE ALLOCATION **STRATEGIES AND TIME SCALES**

Klaus Moessner (University of Surrey, United Kingdom),
George Dimitrakopoulos, Panagiotis Demestichas (University of Piraeus, Greece),
Jijun Luo (Siemens, Germany), David Grandblaise (Motorola, France)
Oriol Sallent (Technical University of Catalonia, Spain), Clemens Kloeck (University of Karlsruhe, Germany)

ABSTRACT

The heterogeneity of the radio environment provides considerable obstacles when aiming for best possible usage of radio resources. The different mechanisms and radio resource management approaches of broadcast, cellular or even ad hoc networks have been optimized for their individual systems, but do not provide a sufficiently efficient performance when looking at the overall radio resource and spectrum usage. This paper describes the E²R projects approach towards a hybrid radio and spectrum resources management scheme capable to support the dynamic allocation of radio resources in a composite radio environment. The paper describes the individual approaches, matches them to their applicability-time-scale and introduces the overall hybrid scheme and its mechanisms.

1. INTRODUCTION

One of the main objectives of the work undertaken in the E²R Project is to facilitate the most efficient radio resource utilisation possible, while providing a “seamless experience” to the mobile users. Targeting this, it is essential to bridge the gap between different radio access schemes and their individual radio and spectrum resource allocation mechanisms. With this working assumption, and the aim to facilitate a more dynamic allocation of spectrum, different resource optimisation techniques have been defined and initially evaluated. These techniques range from the short term allocation of radio resources between different administrative domains, to the more mid-term dynamic allocation of spectrum between the different Radio Access Technologies (RATs) of one operator to the more complex allocation and management of radio resources between the access networks of different operators, to the fully dynamic radio planning that reacts to conditions and requirements and enables a ‘longer term’ allocation within a geographical area. Early investigations in E²R [1-3] have shown that each of the individual problems of resource utilization requires a different approach to achieve the optimal resource allocation. These initial investigations were followed by the definition of the basic functional architecture modules capable to provide and support the required functions [4].

Allocation of Spectrum and Radio Resources depends on a number of parameters and has to be seen in different

dimensions, while some allocation (and optimization) strategies may work in the temporal, they may not be optimal in the spatial dimension (and vice versa). Furthermore, the structure and principles of the range of networks may be divergent (i.e. centrally organized vs. decentralized). This paper discusses the main features and applicability time scales of the range of different dynamic radio resource allocation strategies and techniques investigated in E²R, including:

- Dynamic Network Planning and Management
- Advanced Spectrum Allocation based on auctions
- Resource auctioning between different operators
- Joint Radio Resource Management

The paper describes the conceptual approach devised to implement the time scales in which any of the technologies are used for each allocation case. These include: very short term, short term, medium and long term dynamic radio resource allocation. The structure and basic interworking and system requirements of the E²R hybrid radio resource allocation framework are described and discussed.

2. THE E²R CONCEPTUAL FRAMEWORK FOR DYNAMIC RADIO RESOURCE ALLOCATION

One of the main conditions for the dynamic radio resource allocation approach followed in E²R is the assumption that most network elements (including terminals) provide a degree of reconfigurability that allows the change of a minimum of radio parameters (i.e. the level of Reconfigurability required should, ideally, support the separation of the classical service-RAT-spectrum triple).

The main mechanisms investigated build a coherent framework for spectrum and radio resource allocation that facilitates flexible allocation of radio resources in different spatial and temporal situations. In the temporal domain, technologies like advanced spectrum management and joint radio resource management are considered to impact the very-short and the short term allocations, while dynamic network planning and management (DNPM) is designed to facilitate the medium and longer term dynamic planning and allocation of resources to different services and radio access technologies.

Following the concepts already well established in literature for horizontal (intra-system) and vertical handovers (inter-systems), the approaches for resource efficiency proposed by E²R are based on the principle that the classical combination of “service-RAT-spectrum” becomes dissolved and services can be delivered using any RAT or using parts of the spectrum for which they were not foreseen. This separation of the classical triple provides the possibility for diagonal handovers, which in turn will give operators (referring to the general role of an operator rather than the ‘legal’ entity) the opportunity to diversify their services while optimally distributing traffic loads between different radio networks and maximize the overall usage of the available spectrum.

According to intermediate simulation results [5], the investigated mechanisms enable best possible use and exploitation of the different portions of spectrum, they consider spectrum collaborations between different radio access systems/ technologies as well as inter-operator collaborations. The initial research results show and underline that such flexible handling and use of radio resources will increase spectrum efficiency significantly (numerical expression of the gains depends on the system scenarios).

The approach includes the introduction of new algorithms and also the introduction of an enabling (network) architecture to implement and support these algorithms. Eventually, the foreseen network architecture must support scalable and reconfigurable network elements with reactive and dynamic resource management solutions, cost effective network deployment and sufficient equipment capability. The reconfiguration task will not only be in the terminal side, but also the network will need to support this (i.e. facilitating the aforementioned split of the “triple”. Early results promised that, when considering the reconfiguration features of network entities, Dynamic Network Planning and flexible network Management (DNPM) will give significant gain compared to the classical network deployment case.

The hybrid approach considers Advanced Radio Resource Management (ARRM), Advanced Spectrum Management (ASM) and Dynamic Network Planning and flexible network Management (DNPM), it also leaves room to implement economical mechanisms.

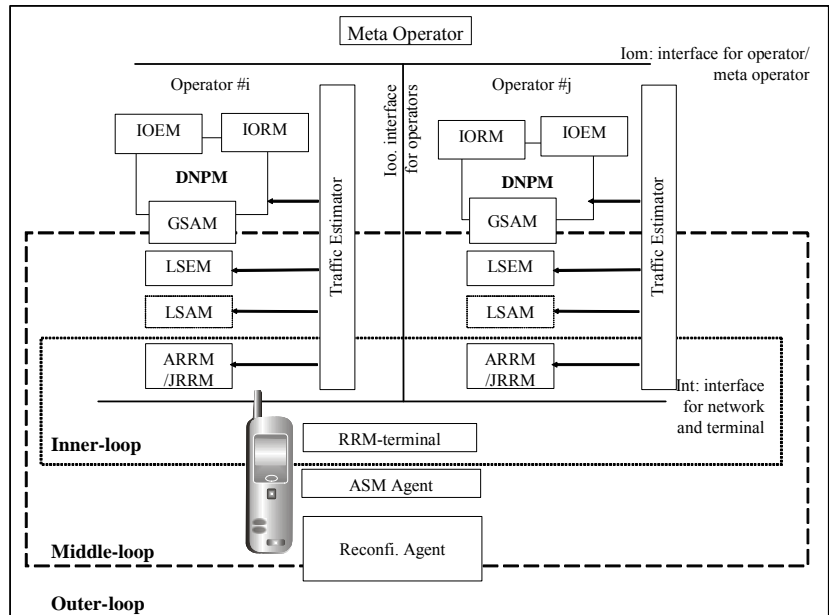

Figure 1: Functional Blocks Overview

ARRM has been designed to handle the optimization of traffic through the available RATs and one of the main concerns of ARRM is the vertical handover between different access technologies. The aim of ASM is to optimize the spectrum allocation adaptively, this includes the optimization of guard bands between the Radio Access Technologies (RATs). Finally, DNPM algorithms deal with the dynamic radio cell behavior through power allocation and antenna techniques.

The functionalities of DNPM, ASM and ARRM are closely interlinked and coupled (see [Figure 1](#)), and the interworking of these three techniques should be considered as three interlocked loops. Each loop reacts and relies on the output parameters of the neighbouring ones. The more a loop is located to the centre of a system, the faster is their reactive time, hence the shorter becomes their ‘reallocation speed’. Therefore the entities of the middle and inner-loop should be locally decentralized in order to minimize reallocation delays. The function of the outer-loop however may be executed in more centralized manner, e.g. for GSM/UMTS by an entity located within the core network.

3. FUNCTIONAL ELEMENTS FOR A HYBRID DYNAMIC RESOURCE ALLOCATION APPROACH

Following this looped, or encapsulated approach, within the outer-loop the network will first be planned and the DNPM will give recommendation to the operator about the needed spectrum in time and space. An entity within the operators’ domain, i.e. the Inter Operator Economic Manager (IOEM)

will decide how to trade spectrum based on the advice of an “Inter Operator Resource Management” (IORM), see Figure 1. The IOEM can offer, or request for spectrum (radio resources) depending on expected traffic. DNPM plans the network based on the spectrum trading results whereby the Global Spectrum Allocation Management (GSAM) calculates the best settings for spectrum division between the operator’s RATs. This calculation takes place on a long-term basis and depends on the parameters provided by the mechanisms within the middle-loop.

DNPM is specified with two phases, i.e., the planning phase and the management phase. The two phases implement the collection of data from the networks and provide implementation parameters to the middle and inner loops. In the middle-loop a Local Spectrum Economic Manager (LSEM) trades the spectrum of each base station to the users. Based on the trading results the Local Spectrum Allocation Management (LSAM) assigns the RATs operated/used by each spectrum user the gained radio resources as a number of Generic Resource Elementary Credits (GRECs) which are the elementary resource units offered per RAT.

The ARRM reacts fastest and therefore represents the inner-loop. Its task is to trigger and manage the vertical handover and optimize spectrum usage using traffic splitting over different RATs. If a user does not need the whole spectrum gained, the “unused” spectrum can be reused by other users. In this case the ARRM triggers the LSAM in the middle-loop to rearrange the spectrum.

Figure 2 provides a classification of the above introduced functions in the space time domains and related business models.

4. SYSTEM OPERATIONS

Traditionally, mobile operators have designed and deployed the radio access networks to cover the traffic demand of the planned services in a static approach, considering the busy hour traffic in each geographical area. This means that the operator installed as many base stations as needed to serve the maximum demand within such zone. In doing so, conventional network planning methods consist of a few predefined phases, these include initial dimensioning as

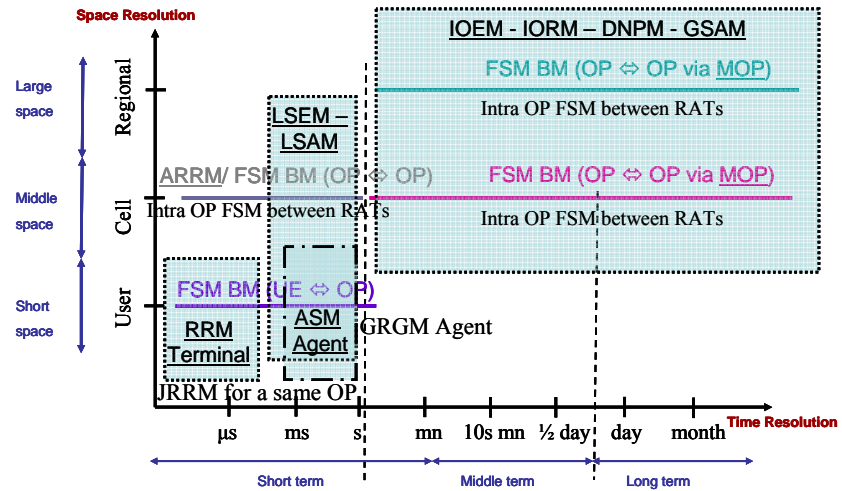

Figure 2: Business models and Function Classifications in the space time domains

well as the detailed planning, mostly with the help of an appropriate planning tool. Such methods can be applied only prior to the network deployment. However, reconfigurable networks have the capability to continuously transform to be able to serve the time and space variant demands. Moreover, in such networks, there will be no clear separation between planning and management, hence the concept of DNPM to guarantee for the best possible planning design, not only before network deployment, but during network operation.

Assuming that operators do their own licenses to operate different RATs and that they have deployed radio access infrastructure for both licensed and unlicensed systems, it is crucial that the resources can be dynamically handled and the allocations can be managed according to the demands rather than the ‘busy hour’ predictions.

One of the typical situation for an operator in Europe is to have a license for GSM and other license for UMTS-FDD at the same time (most operators in that situation would have as well some spectrum to operate UMTS-TDD), and some of them employ WLAN access points to complement their mobile networks. A network planning tool to cater for flexible planning in such situation has to consider GSM/GPRS and UMTS-FDD as well as WLAN RATs in order to test the performance of allocation algorithms for such heterogeneous network.

DNPM consists of a planning phase and a management phase. During the initial planning phase, feasibility of

setting radio interfaces; location of base stations; antenna patterns; coupling structure among sub-networks; policy of JRRM; and statistic values of required spectrum in different scenarios with available RATs are developed. In the management phase, radio network elements are subject to be reconfigured. Reconfiguration is triggered by the management entities, e.g., the network element manager, so that self-tuning of a radio network targeting optimal parameter settings can be carried out.

The management functionality to support reconfiguration decisions needs to decide on the critical issues following three steps: first, detect the need for a reconfiguration (when to perform it), second, find a better configuration (what to reconfigure) and third, enforce the decision within the participating networks (how to perform it). Detailed application examples can be found in [5].

While DNPM makes decisions for longer term allocations, ASM dwells in medium term allocations and the approach is based on the assumption that spectrum itself is not scarce but is rather under-used or not appropriately used by the radio access technologies (RATs). With this assumption, and the tendency towards a secondary spectrum market, ASM creates new opportunities for additional spectrum usage. Some substantial temporal traffic patterns variations have been observed for cellular voice service [6][7], and TV broadcast systems [8]. Some other measurements have outlined the existence of “white spaces” into spectrum at lower temporal resolutions (milliseconds to minutes) [9]. These observations are all the more interesting when considering these observations into a business context. Indeed, the revenue for an operator is highly connected with the amount of time that the communications channels are being occupied, raising high interest in a secondary spectrum usage.

As such, secondary spectrum usage is a joint economic and technical problem. However, the technical feasibility of flexible spectrum sharing is a prior condition to any economic (business model) consideration. Regardless of the spectrum ownership, the technical problem aims at assigning spectrum flexibly between different operators and/or different RATs with the necessary interference control and management. On the other side, the economic aspects look at how spectrum sharing access and use contention issues can be dealt between primary and secondary operators on a secondary market.

Initial work in both of these aspects has been addressed in [10-11]. The work in E²R tackles both the economic and technical aspects. This work approaches the spectrum sharing problem with a distributed control and management

solution perspective. The results (presented in [5]) show how ASM complements DNPM by implementing medium term allocations of spectrum to the different RATs within the composite Radio environment.

Finally ARRM is intended to achieve an efficient usage of the joint pool of the radio resources available, belonging to a variety of RATs in a certain service area. The proposed Joint RRM (JRRM) scheme incorporates two main radio resource management functions: Admission Control (i.e. the functionality set to decide whether a request to set-up a connection can be accepted in the heterogeneous network scenario or not as well as the RAT that the connection will use) and the Bit Rate Allocation (i.e. the functionality set to decide the most suitable Bit Rate or Bandwidth for each RAT and accepted user).

The inputs available for JRRM decisions are mainly:

- RATs deployed, bandwidth available for each RAT and scenario configuration (i.e. base station maximum transmitted power level, code sequences available in case of WCDMA based RATs, etc.)
- Measurements coming from the different RANs (e.g. load levels) as well as measurements coming from the User Equipments (UEs), such as the received power levels, the path loss or the Ec/Io (chip energy over noise and interference spectral density) in case of WCDMA based RATs, mobile speed, etc.
- Techno-economical aspects, including operator policies, which may prevail the use of certain RATs in front of others for different reasons (e.g. commercial strategies, radio network ownership, etc.) as well as subscriber profiles and user preferences (e.g. considering QoS versus cost).

In order to envisage proper JRRM algorithm frameworks, it is important to consider that the variety of JRRM inputs belonging to different RATs will provide in general imprecise and very dissimilar information.

5. CONCLUSIONS

The approach described tackles the problem of using the available spectrum and radio resources in the most efficient manner. While earlier approaches only managed to facilitate local optimization (local meaning within one system), the E²R approach tackles the problem on a more global basis by exploiting the possibilities of Reconfigurability and therein the possibility to use the radio resources of all available radio technologies rather than only a single system. The approach presented brings together three optimization mechanisms, each targeting a different area and applying to a different allocation problem. The definition of a hybrid scheme capable to facilitate short, medium and long-term dynamic radio and spectrum resource allocation is only an

intermediate step. While the capabilities and performance of each individual scheme have been evaluated, the performance of the integrated approach has yet to be shown in real world application.

Network Planning Aspects," End-to-End Reconfigurability Project D5.2, December 2004.

6. ACKNOWLEDGMENTS

. This work has been performed in the framework of the EU funded project E²R. The authors would like to acknowledge the contributions of their colleagues from E2R consortium.

7. REFERENCES

- [1] J. Luo, etc., Feasibility Study of the Dynamic Network Planning and Management in an End to End Reconfiguration (E2R), WWRF, Peking, China, 26-27, Feb., 2004.
- [2] P. Leaves, et al., "Dynamic spectrum allocation in composite reconfigurable wireless networks," IEEE Communications Magazine, vol. 42, pp. 72, 2004.
- [3] R. Agusti, et al. "A Fuzzy-Neural Based Approach for Joint Radio Resource Management in a Beyond 3G Framework", First International Conference on Quality of Service in Heterogeneous Wired/Wireless Networks, Qshine'04, Dallas, USA, October, 2004.
- [4] C. Kloeck, et. al. "Functional Architecture of Reconfigurable Systems", 14th Wireless World Research Forum Meeting, San Diego, CA/USA, 7-8. July 2005.
- [5] E²R WP5, "Algorithms and Performance", deliverable D5.3 of the European E2R Project. June 2005.
- [6] Almeida S, et al. "Spatial and Temporal Traffic Distribution for GSM", VTC 1999, Fall, pp. 131-135, vol.1.
- [7] Lam, D, et al. "Teletraffic modeling for personal communications services", IEEE Communications Magazine, Vol. 35, Issue 2, Feb. 1997, pp. 79-87.
- [8] Kiefl, B.; "What Will We Watch? A forecast of TV Viewing Habits in 10 years", 1998, New York: The Advertising Research Foundation.
- [9] "Dupont Circle Spectrum Utilization During Peak Hours", A Collaborative Effort of The New America Foundation and The Shared Spectrum Company, 2003.
- [10] D. Grandblaise, et al. "Techno - Economic of Collaborative based Secondary Spectrum Usage - E²R Research Project Outcomes Overview", First IEEE International Symposium on New Frontiers in Dynamic Spectrum Access Networks (DySPAN 2005), 8-11 Nov. 2005, Baltimore, Maryland USA.
- [11] E²R WP5, "ASM / ARRM: Concepts, Functional Specifications and First Algorithms for Radio and