

END-TO-END RECONFIGURABILITY: KEY ACHIEVEMENTS AND LEARNING OF PHASE 1 (2004-2005)

Didier Bourse, Karim El-Khazen, Remy Pintenet (Motorola Labs, France)
Nicolas Berthet (Thales Communications, France)
Joerg Vogler (Panasonic European Laboratories, Germany)
Nikolas Olaziregi (King's College London, UK)
Jorg Brakensiek (Nokia Research Center, Germany)
Klaus Moessner (University of Surrey, UK)
Nancy Alonistioti (University of Athens, Greece)

ABSTRACT

The objectives of the End-to-End Reconfigurability (E²R) research project are to bring the full benefits of the valuable diversity within the radio eco-space, composed of a wide range of systems (such as cellular, wireless local area and broadcast), and to devise, develop and trial architectural design of reconfigurable devices and supporting system functions to offer an expanded set of operational choices to the different actors of the value chain in the context of heterogeneous mobile radio systems. The E²R project will help operators to better exploit their investments on infrastructures and terminals and ensure that the infrastructure will be flexible and reconfigurable to accommodate evolving standards, applications and the end-user needs. E²R is seen by many actors of the wireless industry as a core technology to enable the full potential of beyond 3G systems. It has the potential to revolutionize wireless just as the PC revolutionized computing. This paper presents the E²R research project, its architectural framework, as well as the key achievements in the different technical areas in 2004-05.

1. INTRODUCTION

Within the End-to-End Reconfigurability (E²R) [1], innovative research, development and proof of concept are sought in an end-to-end aspect, stretching from user device all the way up to Internet Protocol, and services, and in reconfigurability support, intrinsic functionalities such as management and control, download support, spectrum management, regulatory framework and business models. End-to-end reconfigurability systems will provide common platforms and associated execution environments for multiple air interfaces, protocols and applications, which will yield to scalable and reconfigurable infrastructure that optimize resource usage, increased network and equipment capability and versatility by software modifications. The

users will benefit from these capabilities by reaching the required service at times and places when and where needed at affordable cost.

The End-to-End Reconfigurability (E²R) project is undertaking a long-term 6-year lifetime with ultimate goals of research, design and proof of concept of reconfigurability. Launched within the 6th Framework Programme (FP6) [2] of the European Commission (EC), the Phase 1 (E²R I) (2004-05) is a definition phase identifying stumbling blocks, consolidating the heritage of former work, and further developing concepts and solutions. The brand-new concept of this first phase was to bring together some key independent research activities initiated in former EC 5th Framework Programme (FP5) and to assess the feasibility of an integrated system for the support and provision of reconfigurability. The Phase 2 of E²R that will run in 2006-07 will concentrate on most promising solutions identified in E²R I and will assess any emerging new technologies, while in parallel evolving towards integrated framework. This project is including major key European players in the domain of Reconfigurability, Software Defined Radio and Cognitive Radio, who have an accurate understanding of the state-of-the-art from various projects and bodies [3].

Reconfigurable equipment and systems will provide much higher flexibility, scalability, configurability and interoperability than currently existing mobile communications systems. Reconfiguration will stretch over all OSI layers, on open platforms where the complete protocol stack will be subject to reconfiguration. To achieve the E²R project ambitions, three major challenges were identified in E²R I: (1) Transforming embedded flexibility into end-to-end reconfigurability, (2) Capturing the newly enabled functionalities of E²R into valuable benefits, and (3) Finding right balance between integrated versus distributed approaches. These axes are driving the definition of an

architecture and design of reconfigurable and flexible system concepts that enable seamless and transparent communication across these heterogeneous environments. An active cooperation between end-users, operators, manufacturers, service providers and new comers is needed to firm up the definition of the most appropriate distribution of intelligence between reconfigurable terminals and networks. E²R is thus contributing to the realisation of the ambient space through which a modern society interacts and communicates with key capabilities of the radio eco-system and finally actively influence European industrial and economic competitiveness.

This paper is presenting the E²R architectural framework in Section 2 and the E²R research project in Section 3. The key achievements across the different technical workpackages are depicted in Section 4. Finally, in Section 5, a short summary concludes the paper.

2. E²R ARCHITECTURAL FRAMEWORK

An important trend within the ambient space is the emergence of communication systems that are composed, to a significant degree, of dynamically configured distributed components, whereby optimised resources should be anticipated while keeping its complexity hidden. Additionally, in the past years, the wireless telecommunications sector has lead to the development of a wide range of technologies like 2G, 3G, WLAN, WMAN and DVB and its associated equipments. This represents valuable diversification of the radio eco-space that has already made a technology push towards multimode devices and produced significant investment into research of new technologies, services and business models adapted for collaborative heterogeneous radio systems. The ultimate vision of E²R is to reach all-IP fully integrated networks with reconfigurable equipment and associated discovery, control and management mechanisms. Within this ambient space, the users will benefit from end-to-end reconfigurability by reaching the required services, at affordable cost, in different heterogeneous contexts, using diverse equipments and through several technologies. The E²R architectural framework, enabling the seamless experience, is depicted in Figure 1, where the users are considered to be at the centre of the future telecommunications environment, using heterogeneous devices, (such as end-user mobiles, personal network equipments...), in heterogeneous environments and contexts (such as home, office, on the move...) and through heterogeneous systems (such as fixed, wireless local area networks, cellular and broadcast technologies...).

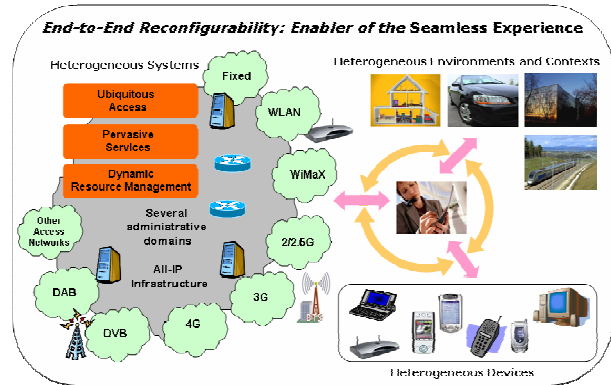

Figure 1: E²R Architectural Framework

3. E²R PROJECT PHASE 1 APPROACH

In order to drive the E²R research work to success, the following technical approach was adopted over the whole duration of the Phase 1: (1) Capture compelling use cases, establish a model architecture of the E²R system and define an overall end-to-end reconfiguration framework, (2) Design and prove the concepts of technical solutions to implement reconfigurability in all the layers of an end-to-end wireless communications system, (3) Develop a flexible, modular and evolutionary proof of concept environment for validation purposes, and (4) Disseminate, contribute to related standardisation bodies, organize training sessions and ensure worldwide recognition of the E²R results. The organisation of technical research adopted by the E²R project is depicted in Figure 2 wherein three main components are introduced.



Figure 2: E²R I Organization of Technical Research

The “E²R System Research, Business Path and Technology Roadmaps” component is focusing towards compelling scenarios and stakeholders requirements of the radio eco-system. The “Core Technology Research, Design and Proof of Concept” component encompasses the technologies needed to transform embedded flexibility into end-to-end

reconfigurability, while finding the right balance between integrated versus distributed approaches. Finally, the “E²R Proof of Concept Evolutionary Environment” component is enabling the validation of the charter of research as a whole, thus establishing the proof of concept of the system within the radio eco-space.

With these different components in place, the charter of the current six technical workpackages (WPs) is the following: WP1 “E²R System Research”, WP2 “Equipment Management”, WP3 “Network Support for Reconfiguration”, WP4 “Radio Modem Reconfigurability”, WP5 “Evolution of Radio Resource and Spectrum Management”, and WP6 “E²R Proof of Concept Evolutionary Environment”. The E²R research achievements in 2004 have been focused in the different domains represented in Figure 3. These achievements and associated innovation aspects are detailed on the E²R public website [1].

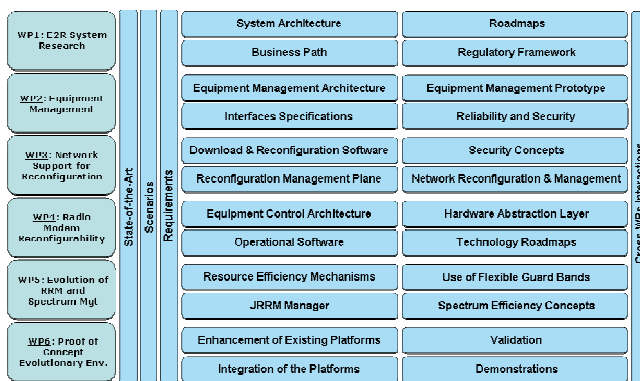

Figure 3: E²R WPs Research Domains and Thematics

4. E²R RESEARCH FIELDS ACHIEVEMENTS

Each of the technical workpackages had main achievements, as described in this section. All WPs carried out at the beginning an extensive analysis of the state-of-the-art. Moreover, WP1 defined three high level scenarios (ubiquitous access, pervasive services, and dynamic resource management) taking into account the inputs from the other technical WPs.

The main achievements, as highlighted in Figure 4, of “E²R System Research” (WP1) include the following:

- Requirements: Use of the three high level scenarios to derive the system requirements and identification of twelve system capabilities.
- System Architecture: Analysis and identification of functions and data necessary to satisfy the requirements/capabilities, start of the high level functional architecture definition.

- Business Path: Definition of E²R business framework and analysis of business relationships in the scenarios, study of existing market and foreseen future evolutions, study of operators considerations, elaboration of three questionnaires (user, network operator, equipment vendors), and organisation of two business model workshops.
- Roadmaps: Identification of relevant existing or emerging techniques, technologies and standards for defining the technological aspects of the radio eco-system. Considerations of the possible use and evolution trends have been drawn.
- Regulatory Framework: Preparation of a regulatory questionnaire aiming to evaluate the global regulatory tendencies. The concept of responsibility chain was introduced, investigating the relations of actors involved in (re)configuration and identifying the potential threats and their associated responsibilities.

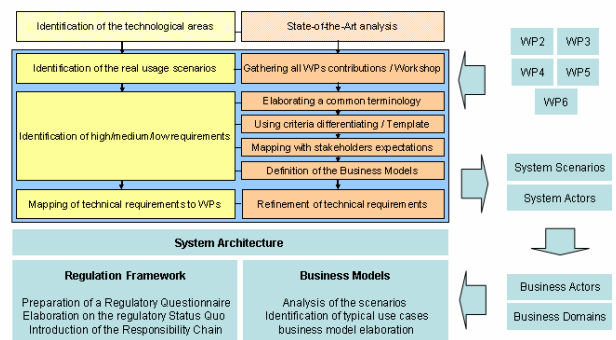

Figure 4: System Research

The main achievements, as highlighted in Figure 5, of “Equipment Management” (WP2) include the following:

- Requirements: Definition of the technical requirements for the local equipment reconfigurations based on the scenario and use-case analysis.
- Equipment Management Architecture: Development of the initial overall equipment management architecture including definition of modules: Configuration Management Module (CMM), Configuration Control Module (CCM) and Execution Environment (EE).
- Interfaces Specification: Draft interface specification including internal interfaces to management and reconfiguration entities in the device and external interfaces to reconfiguration entities in the network.
- Equipment Management Prototype: First high level design specification of the prototype.
- Reliability and Security: Definition of a common security architecture incorporating all entities of a future device, also covering several layers of implementation.

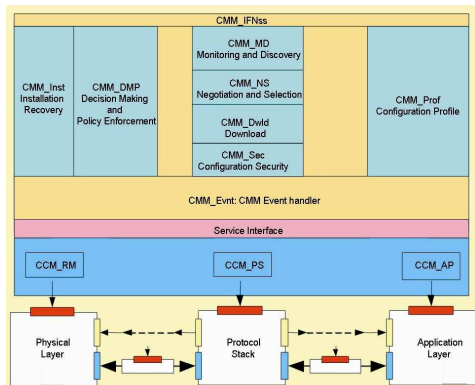

Figure 5: Equipment Management Functional Framework

The main achievements, as highlighted in Figure 6, of “Network Support for Reconfiguration” (WP3) include the following:

- Requirements: Requirements for the radio resource, dynamic network planning and spectrum allocation mechanisms were derived from the technical scenarios.
- Download and Reconfiguration support: Mass upgrade concepts were developed starting from phased approaches for broadcast phases down to dedicated download phases and its application for MBMS.
- Reconfiguration Meta Model and Management Plane: Definition of a meta model as a new lightweight UML profile that captures the requirements, associations, and dependencies between reconfigurability thematic areas and a Reconfiguration Management Plane (RMP).
- Security Concepts for reconfiguration: Initial concepts for software authorization and activation for decentralised reconfiguration and configuration validation were developed.
- Network Reconfiguration and Management: Categorisation of base station reconfigurability and investigations of self-tuning mechanisms.

The main achievements, as highlighted in Figure 7, of “Radio Modem Reconfigurability” (WP4) include the following:

- Requirements: Requirements specific to physical layer and baseband modules have been identified and partly modelled in UML.
- Technology Roadmaps: Evaluation of technological perspectives of software radio with respect to the physical layer and their enabling technologies through analysis of available technology roadmaps.
- Hardware Abstraction Layer: Hardware abstraction is the key for easy integration (migration path) of the developed concepts including current legacy architectures as well as high-end reconfigurable baseband and RF components. A concept of physical and logical device drivers has been developed.

- Physical Layer Architecture: Partitioning of the physical layer into functional, reconfigurable blocks for radio frequency front-end and base-band signal processing with scope for both terminal and base-station.
- Operational Software: Temporal scheduling of HW/SW resources requires appropriate operational software support. Scheduling mechanisms to coordinate involved component are under development.

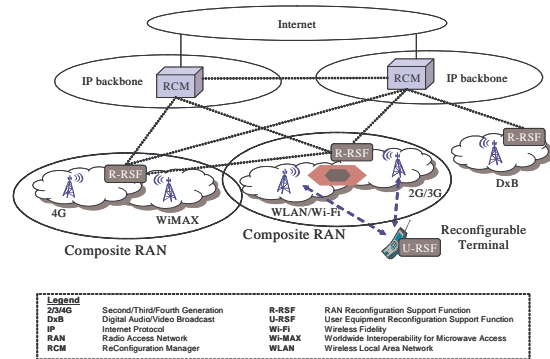

Figure 6: Network Architecture

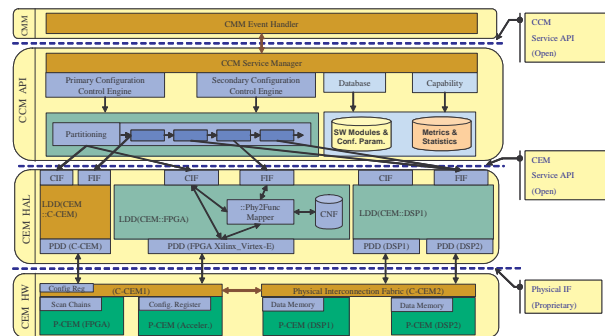

Figure 7: Equipment Control Functional Framework

The main achievements, as highlighted in Figure 8, of “Evolution of Radio Resource and Spectrum Management” (WP5) include the following:

- Requirements: Requirements for the radio resource, dynamic network planning and spectrum allocation mechanisms were derived from the scenarios.
- Resource Efficiency Mechanisms: This includes the continuous assessment and improvement of potential sharing mechanisms and evaluation of overall gains.
- Joint Radio Resource Management (JRRM) Manager: A scheme, mechanisms and manager to coordinate the resources across different radio access schemes were developed, initially evaluated and initial proof of its efficiency was given.

- Use of Flexible Guard Bands: WP5 developed an initial approach towards the concepts to use flexible guard bands.

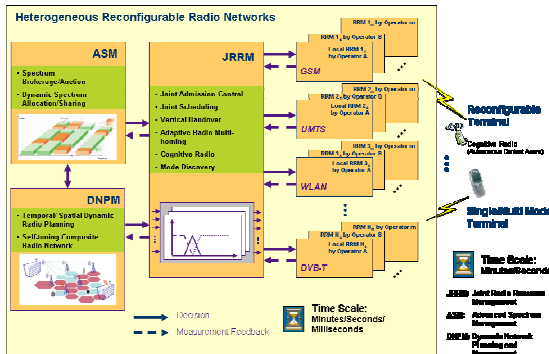

Figure 8: Advanced Resource Management Framework

The main achievements, as highlighted in Figure 9, of “E²R Proof-of-Concept Evolutionary Environment” (WP6) include the following:

- Requirements: The system architecture and specification of the content of the proof of concept has been defined.
- Enhancement of Existing Platforms: The existing FP5 platforms were enhanced. Definition of security architecture for authentication of downloaded patch and first implementation of a security server.
- Integration of the Platforms: Those enhanced platforms were integrated in a coherent way to form an end-to-end reconfiguration demonstrator.
- Validation: The resulted demonstrator was used to validate one of the scenarios that have been identified in WP1, i.e. the software upgrade scenario.
- Demonstrations: Successfully demonstrated prototyping environment in several events: IST Mobile Summits 2004 and 2005, E²R Workshops, and E²R Demonstration Day.

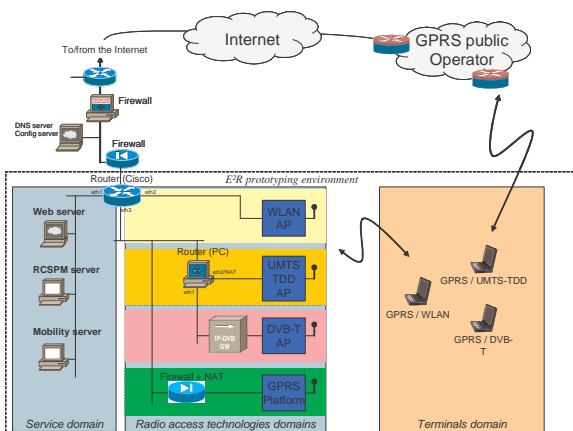

Figure 9: Prototyping Environment Architecture

5. CONCLUSIONS

This paper has presented the E²R research project, partly funded by the European Commission, and the main key achievements in the different research areas. The E²R project aims at bringing full benefits of the radio eco-space diversity making heterogeneous environments transparent, flexible and intelligent. Benefits of end-to-end reconfigurability could be enabled if and only if the reconfigurability is considered simultaneously at all layers, for all involved actors. Indeed, the most advanced reconfigurable equipment will bring very limited advanced features if the network or the services are not designed to support them. Similarly, reconfigurable networks will bring limited advantages if designed without considering reconfigurable equipment capabilities. E²R is seen by many actors of the wireless industry as a core technology to enable the full potential of beyond 3G systems. It has the potential to revolutionize wireless just as the PC revolutionized computing.

ACKNOWLEDGMENTS

This work has been performed in the framework of the European funded project E²R. The authors would like to acknowledge the contributions of their colleagues from E²R consortium.

REFERENCES

- [1] FP6 End-to-End Reconfigurability (E²R) Integrated Project (IP), <http://www.e2r.motlabs.com>
- [2] Community Research & Development Information Service (CORDIS), 6th Framework Programme, <http://fp6.cordis.lu/>
- [3] Software Defined Radio Forum (SDR Forum), <http://www.sdrforum.org>

